

Teknic System Manual

SST SERVO SYSTEM

INCLUDES INFORMATION ON:

SST-1500 SERVO DRIVE;
SYSTEMS/MOTORS—
[1726, 2330, 2348, 3437, 3450, 3462, 3471, 4975P AND 4975T];
SST-3PS12-75 AND SST-EMF-75 POWER SUPPLIES.

V3.3/MARCH 30, 2001

THIS PAGE INTENTIONALLY LEFT BLANK

TABLE OF CONTENTS

OVERVIEW	1
Benefits:.....	1
ELECTRICAL INSTALLATION	5
Electrical Isolation & Grounding	7
The Golden Rules of SSt Electrical Installation	8
Connecting your controller to the SSt-1500.....	11
Connecting a Motor to the SSt-1500	15
Controller signalling details	16
Power Supply	26
MECHANICAL INSTALLATION	33
Motor Outline Drawings:	34
ENCODER FEEDBACK IN YOUR APPLICATION	45
SST-QUICKSET™ CONFIGURATION AND INTEGRATION SOFTWARE.....	53
Required Hardware	53
SSt-QuickSet™ Installation.....	53
Using SSt-QuickSet™	54
OPTIMIZING SYSTEM PERFORMANCE (TUNING)	57
Servo Glossary.....	57
The SSt servo drive Compensator (Control Algorithms).....	59
SSt servo drive Built-In Instrumentation.....	59
Tuning for Performance	63
Tailoring the Response to Your Application	70
TROUBLESHOOTING YOUR MACHINE	75
Problem Table of Contents.....	76
DRIVE SHUTS DOWN (GREEN LED BLINKS SLOWLY)77	
Tracking Error Shutdowns Occur	77
RMS limit shutdowns occur and/or Motor Runs Hot	79
I/V shutdowns occur	85
LACK (OR PARTIAL LACK) OF MOVEMENT	88
Motor Will Not Move.....	88
MOVEMENT NOT SMOOTH	92
Axis Jerks at End of Move	92
Axis jerks at beginning of moves.....	95
Motion erratic (“jerky”) while moving at constant velocity	96
Large velocity/torque ripple or “cogging” is evident	97
MOVE LENGTH INCORRECT/UNREPEATABLE	98
Motor shaft moves wrong, but repeatable, distance.....	98
Motor shaft moves an unrepeatable distance	99
Load moves an incorrect, unrepeatable distance.....	102
Motor “walks” when no step pulses are given	103
TORQUE SEEMS LOW	104
Motor moves but does not have full torque.....	104
Motor loses torque (or performance degrades) after running ..	106
MISCELLANEOUS (LOW PROBABILITY PROBLEMS) 108	
Axis “sings” or “whines”	108
Limit switches don't work	110

Encoder error shutdowns occur.....	111
Drive resets when motor attempts to move	114
Thermal protection Shutdowns occur	115
APPENDIX A: SST-1500 SPECIFICATIONS	116
APPENDIX B: CONNECTORS	117
INDEX.....	118

OVERVIEW

Congratulations on your investment in SSt servo drive: today's way to get the easy digital control and low cost of a stepper motor system, but with state-of-the-art DSP driven, sinewave-commutated brushless servo performance.

Unlike most servo drives that control only torque or velocity, SSt servo drive also controls position by using digital "step and direction" pulses as input. And it's the only high-performance servo on the market that can compete on a price basis with open-loop stepper motor systems.

So where's the catch? How can a servo offer state-of-the-art features and performance, yet cost so little? Well, it's the combination of several factors working together to increase performance, while simultaneously lowering product cost, that explains this apparent contradiction:

1. To increase performance, SSt servo drive leverages the extraordinary processing power of Digital Signal Processors (DSPs). With the number crunching ability of DSPs, Teknic has implemented advanced control algorithms that have been previously impractical. For example, SSt servo drive uses PIV control with dual feedforward terms, instead of the more common, but inferior, PID algorithms. We have also implemented several innovative and proprietary algorithms using fuzzy logic, among other techniques, to achieve superior performance.
2. To reduce cost, we have replaced expensive hardware, wherever possible, with DSP firmware. For example, even the SSt servo drive's current loops are fully digital; in this case, not just reducing cost, but also enhancing performance and improving reliability at the same time.
3. Teknic designed SSt servo drive exclusively for OEM users, allowing us maximize product value specifically for them. And because we don't sell to end-users, we don't need distributors, thus eliminating the cost of middlemen who add at least thirty percent to your cost. Our sales engineers are all factory-direct specialists, assuring you the top-notch technical support and applications advice for which Teknic has earned respect.

So now that you know how a brushless, positioning servo drive with state-of-the-art features can cost as little as an open-loop microstepper, how about some specifics? How do these features benefit you, and how does the SSt servo drive's performance compare with other servo solutions?

BENEFITS:

EXPANDED TORQUE-SPEED LEADS TO HIGHER THROUGHPUT

The throughput of your machine is directly related to the power your drive motors can produce. The efficiency and dynamic performance of SSt servo drive's closed-loop vector torque control gives you higher torque and speed for measurably greater power than most servos twice its price, and typically four to eight times as much power as a stepper motor of equivalent cost or size. This, coupled with the SSt servo drive's

fast settling performance, can more than double the throughput of your machine in typical applications.

Best of all, if you now use steppers, you can, for the first time, get this increased throughput with no increase in cost, and without rewriting your software or retooling your mechanics.

HIGH BANDWIDTH, CLOSED-LOOP OPERATION FOR CONSISTENT PERFORMANCE

For those of you familiar with the performance attainable with high-bandwidth servos, you'll be excited that SSt servo drive offers a control bandwidth that is literally twice as wide as most other servos, regardless of price. (It has an attainable velocity bandwidth of greater than 420 Hz and a position bandwidth above 115 Hz!) This means that the SSt servo drive's dynamic performance-settling time, tracking accuracy and dynamic stiffness-is superb. The exclusive IMT adaptive control feature not only increases the robustness of control but also allows you to increase the integral gain for even more stiffness.

To see what wide bandwidth means in the real world, picture one OEM's new design: An SSt servo driven IC handler that moves chips at 240 inches/sec, decelerates at 11,680 in/sec² (over 30 G's!) while maintaining a tracking accuracy of better than 18 mils, and settles to a stop less than 2 milliseconds after receiving its last step input! Even if your application is not this demanding, you can be comfortable that the SSt servo drive's wide bandwidth will provide you with enough headroom to assure exceptional servo control under all conditions.

Stepper users will appreciate that the SSt servo drive's closed loop operation prevents it from ever losing a step. You can feed SSt servo drive any number of steps, at virtually any rate or acceleration and, even if the SSt servo drive falls behind, it will never lose a step. In contrast to "closed loop" stepper motor systems (i.e. those with encoder position verification), SSt servo drive corrects for errors continuously, not just at the end of a move. So there is never any waiting for a position "trim" procedure to complete.

SSt servo drive is also "stiffer" than a stepper system. Twenty times stiffer, in fact, for small disturbances at rest, and up to one hundred times stiffer when operating at speed.

FREEDOM FROM SERVO JITTER AND "HUNTING":

A common complaint of servo users is that if they increase their loop gains to get the dynamic performance they want, their motor won't stay still at its commanded position. It becomes very jittery and tends to hunt back and forth between adjacent encoder counts. the SSt servo drive's Anti-Hunt™ feature employs a proprietary algorithm that uses fuzzy logic and the advantage of DSP processing power to virtually eliminate servo jitter.

ULTRA-SMOOTH MOTION WITHOUT TORQUE RIPPLE OR "COGGING" EVEN AT LOW SPEED:

the SSt servo drive's sinewave commutation allows the magnetic field of a motor stator to be positioned within a few arc-minutes of its optimal value, compared to the sixty degrees of stator field resolution in most brushless drives. Since the optimal angle between the rotor and stator fields can always be achieved, torque variations are greatly minimized.

Moreover, the SSt servo drive's DSP constantly calculates the proper current-voltage phasing to maintain this optimal magnetic angle regardless of motor speed or load. SSt servo drive also continually auto-calibrates its current sensors to minimize inaccuracy and drift. Combined, these techniques generate accurate and consistent torque under all conditions, producing fluidly smooth motion. We have customers with high-resolution imaging applications who have upgraded to SSt servo drive just for this benefit alone.

SIMPLICITY AND EASE-OF-USE-FASTER TIME-TO-MARKET AND EASIER, LOWER COST PRODUCTION:

Compared to most servo systems, the SSt servo drive's fully digital design means that you have no mysterious pots to tweak, or DIP switches to set, or jumpers to configure. The SSt servo drive's configuration is stored in non-volatile EEPROM, and easily accessed with a Windows™-based software utility. Configurations can be stored on disc for fast and repeatable setups. SSt servo drive also has built-in stimulus/response instrumentation for easy tuning and system optimization. An oscilloscope is all you need to measure parameters such as velocity, acceleration, tracking, settling time, torque, and more. The effects of changing loads or gain settings are seen quantitatively in real-time there's no guesswork.

Unlike stepper motor systems, no mechanical adjustments to the system are required to get your system to work properly. The mechanical tuning normally accomplished by adding dampers, couplings or by finding "just the right belt" for your stepper motor system are eliminated. What's more, you won't ever be faced with having to add just the right amount of friction, juggling a trade-off between accuracy and resonance suppression. Using SSt servo drive, your system response can be optimized electronically to suit your machine's needs.

SSt servo drive Plus™ can also be used as a cost-effective, high-bandwidth velocity or torque amplifier for use with traditional servo controllers that have a $\pm 10V$ analog command signal. As a servo amplifier, SSt servo drive Plus™ has several features that allow you to build high performance systems with minimum effort.

EFFICIENT, COOL-RUNNING OPERATION

SSt servo drive only uses current when necessary to move or correct for a disturbance, unlike a stepper motor, which requires current at all times to resist disturbances and hold its position. No "current cut-back" mode is required, yet SSt servo drive has faster-responding, more forceful holding torque than any stepper of equivalent size.

The SSt servo drive's motor construction reduces losses at speed caused by hysteresis currents, a major source of reduced output and heating in stepper motors. All of this adds up to cool running and efficient operation. Cooler operation also allows you to use SSt servo drive in heat-sensitive applications.

ENHANCED RELIABILITY BY DESIGN

An SSt servo drive system is inherently reliable for the same reason that it is cost-effective: Teknic's efforts to replace hardware with DSP firmware have resulted in a dramatically lowered parts count. There are fewer parts in SSt servo drive than in most microstepper drives and far

fewer parts than in other comparable servo systems. This low parts count, coupled with conservative thermal design and robotic assembly techniques, makes SSt servo drive very reliable (as well as low-cost).

In addition, SSt servo drive has a host of self-protection features including protection against the following: shorting the motor cable (phase-to-phase or phase-to-ground), thermal overloads, exceeding motor RMS capability, motor jams and others. And to back up all this reliability talk, Teknic offers a standard three year warranty on all drive electronics.

Because SSt servo drive systems are consistent, reliable and smooth, they enhance the operational reliability of your machine. SSt servo drive-powered axes never lose steps, so jams, misfeeds and lost synchronization are things of the past. In addition, your mechanisms are not subjected to high frequency vibrations that can shake things apart. All of this means that you can more confidently stand behind the machines you build.

ELECTRICAL INSTALLATION

The electrical interface of the Sst-1500 servo drive has been designed to minimize installation hassles, however, you will find it quite useful to read through this section of the manual before beginning.

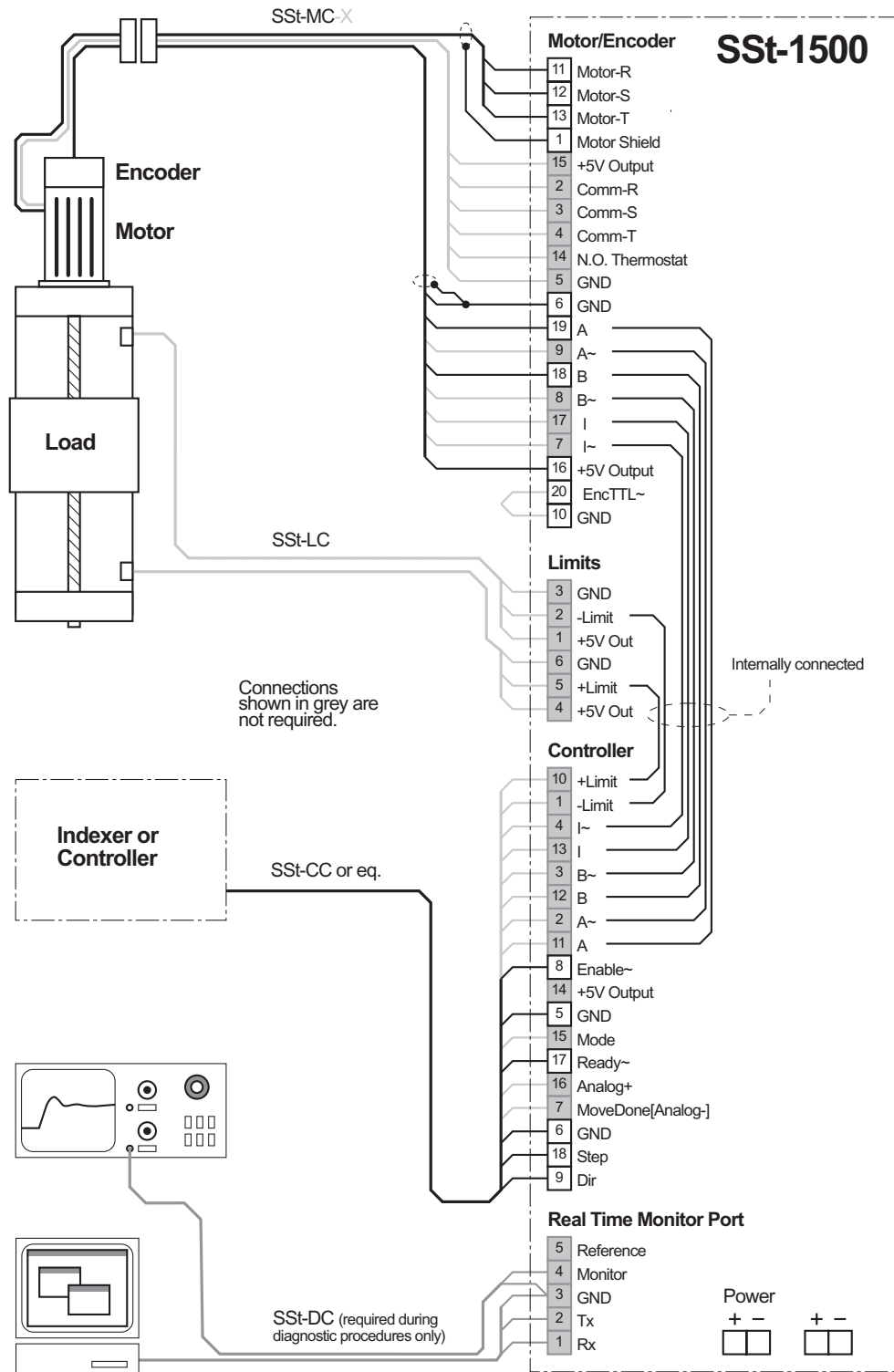

Sst Servo System Conceptual Wiring Diagram

Every effort has been made in the design of the SSt servo drive to reduce the complexity of the required harness. In most cases a single cable connects to the motor, another connects the limit switches, and a third connects to the indexer/controller without any need for tees or other "spaghetti" wiring. Even the main DC power can be daisy chained..

Installing an SSt servo drive System is straightforward- Every effort has been made to reduce your harnessing requirements (only the connections shown with solid wiring are absolutely required)

ELECTRICAL ISOLATION & GROUNDING

In order to eliminate the possibility of ground loops in SSt servo drive systems, the isolated control ground (GND), power circuits and chassis are each electrically isolated from each other as shown below.

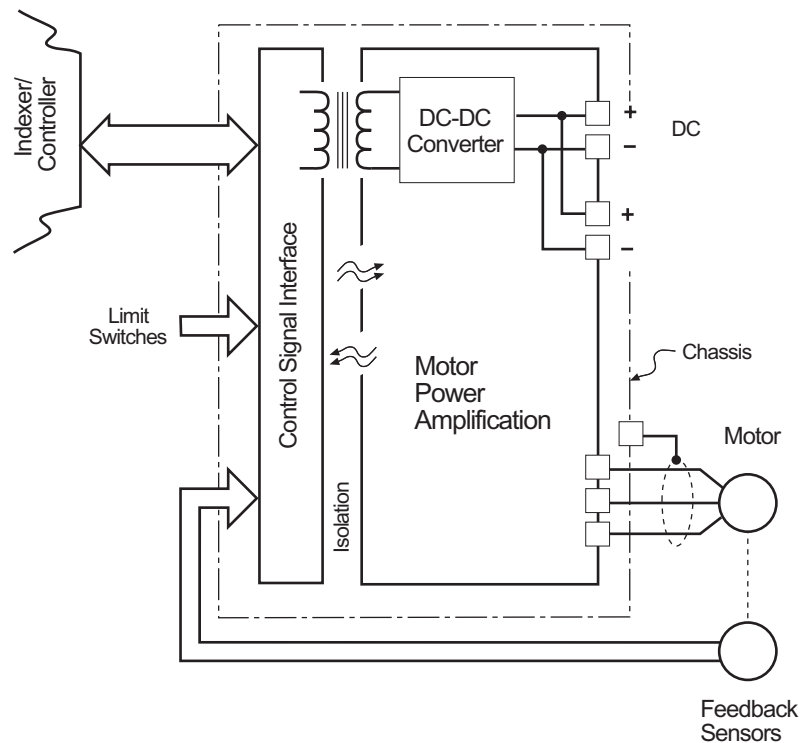

Isolation Diagram

All of the control signals used by the indexer/controller are electrically isolated from the SSt-1500's DC power input and motor output circuits as well as from the SSt-1500's chassis (Case Ground). This feature insures that currents will not be induced into your control wiring by motor and/or power supply currents. You can even daisy chain the power wiring to multiple SSt-1500s while using an indexer/controller without isolated control signals. Not only does this make your wiring simple, it reduces your cost while increasing your system's operational reliability.

To fully take advantage of the isolation you need to be careful to maintain separation between the isolated control ground and power ground. This can be accomplished easily as outlined in the "Golden Rules" section below.

THE GOLDEN RULES OF SST ELECTRICAL INSTALLATION

Teknic has developed the following set of 15 simple “Golden Rules” for SSt servo system installation. Following these rules will prevent potential electrical problems—The installation will be largely immune to electrical noise, generate a minimum of electrical interference, meet safety requirements and perform as expected. *If you read only one thing in this manual these rules should be it!*

Rules 1,6, 8, 11, 13 &14 are especially important for proper operation and have been highlighted in gray.

POWER

1. Drive power should be provided by a bulk, unregulated DC power supply (transformer, rectifier & capacitor). Do not use a switching power supply.
2. Daisy chaining power through SSt servo drive’s power connectors is perfectly acceptable. Because of the full electrical isolation between the SSt servo drive’s power and control signals, “star” power distribution is not required.
3. Don’t run the drive power return through the machine’s frame or chassis. Connect the drive power return (negative lead) to the machine frame or chassis *only* at the power supply.
4. Use heavy gauge wire for power cables as shown below:

# SST-1500S IN A POWER CHAIN	WIRE GAUGE REQUIRED	FUSE/BREAKER REQUIRED
1-3	18 AWG	15A time delay (T)
4-5	16 AWG	20A time delay (T)
5-6	12 AWG	30A time delay (T)

5. The quiescent output voltage of the supply (when all of the SSt servo drives are connected and disabled) should be no more than 81.0 VDC. If the output is higher than this, change the input (or output) taps on the power supply’s transformer to lower the voltage. (The SSt servo drives perform a safety I/V shutdown at a minimum of 86 VDC.)

GROUNDING & SHIELDING

6. Ground the SSt drive to the machine frame or chassis using unplated 8-32 threaded inserts in the SSt servo drive’s chassis. **MAKE CERTAIN THESE SCREWS DO NOT PROTRUDE INTO THE CASE MORE THAN 0.3” (7.5mm).**
7. Use shielded cable for all control signal connections: limit switches, the motor’s encoder & commutation signals and the controller cable. The shield should be connected to the SSt servo drive’s isolated control ground (pins 5 and 6 on the controller connector, pins 3 and 6 on the limit switch connector and pins 5 and 6 on the motor connector). The encoder and controller cables should have low capacitance insulation. Low capacitance cable conductors are typically made from polyethylene, foamed polyethylene, Teflon®, FEP, etc. The recommend cable stock shown in the table below has

excellent electrical properties and low cost (for non-flexing applications).

APPLICATION	MFGR./PN	CABLE DESCRIPTION
Encoder & comm. sensor cable for TTL encoders	Belden/9935	10 conductor 24AWG foamed polyethylene conductors, foil + braid shield. PVC jacket.
Controller to SSt cable without encoder signals	Belden/9935	10 conductor 24AWG foamed polyethylene conductors, foil + braid shield, PVC jacket.
Encoder & comm. sensor cable for balanced encoders	Belden/8108	8 pair 24AWG foamed polyethylene conductors, foil + braid shield, PVC jacket.
Controller to SSt cable (with encoder signals)	Belden/8108	8 pair 24AWG foamed polyethylene conductors, foil + braid shield, PVC jacket.
Limit switch cable	Belden/9533	3 conductor 24AWG SR PVC, foil shield, PVC jacket.
Motor phase cable	Belden/8618 —or— Belden/8770	3 conductor 16AWG polyethylene, foil shield, PVC jacket 3 conductor 18AWG polyethylene, foil shield, PVC jacket

8. Connect the controller cable's shield (isolated control ground) to the machine frame of chassis *only* at the controller end of the cable (not at the SSt servo drive end). DO NOT HOOK ISOLATED CONTROL GROUND TO THE MACHINE FRAME OR CHASSIS AT ANY OTHER LOCATION.
9. Don't ground the limit switch circuit to the machine frame or chassis.

MOTOR CABLES

10. Use heavy gauge *shielded* cable for the motor phase wiring. Connect the shield to pin 1 on the SSt servo drive's motor connector (case ground). Cable with 18AWG conductors can be used up to 12 foot cable lengths. Longer cables should use cable with 16AWG conductors. Cables in excess of 25 feet will begin to affect the torque speed curve of the motors and should be avoided, if possible.
11. When constructing the motor cable, ensure that the shield from the motor phase cable and the shield from the encoder & commutation sensor cable do not touch.

CONTROLLER/INDEXER INTERFACING

12. Use pull-up resistors on the Ready and MoveDone output signals from the SSt servo drive. These pull-up resistors can be connected to a supply voltage of up to 24V.

13. Be sure the step and direction outputs on the controller can sink 12mA or more (to pull-down a 470 ohm resistor connected to 5V)
14. If encoder feedback is desired at the controller set up the controller's encoder input to be consistent with the encoder type used on the *motor*. The SSt servo drive simply passes the motor's encoder signals through to the controller connector, it does not buffer them. So, for example, if the motor has a TTL single ended encoder your controller must be configured to accept this (the A~, B~ and I~ signals will not be active).

STATIC PRECAUTIONS

15. When installing an SSt servo drive you should observe the same static sensitive procedures as you would for any piece of sensitive electronic equipment. Although the SSt-1500 inputs are protected from small amounts of electrostatic discharge (ESD), SSt servo drives should not be considered immune to ESD. The use of wrist straps is recommended during installation. Note that both the isolated control ground and the case ground should be used for grounding the unit for ESD protection purposes during installation.

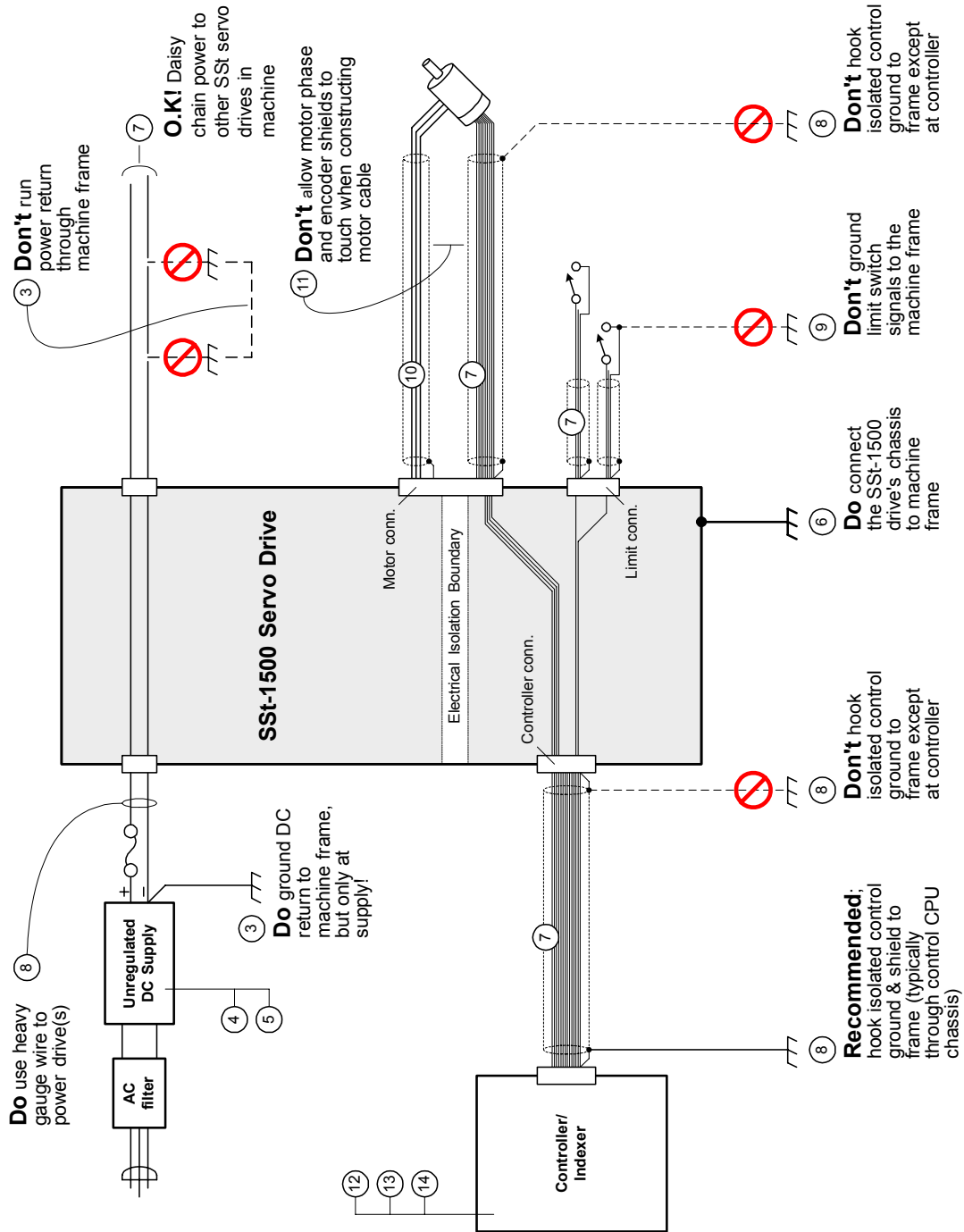

The “Golden Rules” of Installation—Illustrated

CONNECTING YOUR CONTROLLER TO THE SSt-1500

It’s easy to connect your control system to the SSt-1500. One connector provides your system with all of the necessary control inputs and outputs including: Digital command (step&direction), Analog command (+/-10V), Limit switch signals, Encoder signals, [drive] Ready~, MoveDone, and [control] Mode. All of these signals can be connected to your control

system using readily available, inexpensive shielded cable. The SSt-CC cable, provided with Teknic's engineering kits routes *all* of these signals to your controller. Shown below is a more common, simplified, all-digital command interface using inexpensive yet high performance Belden 9935 cable.

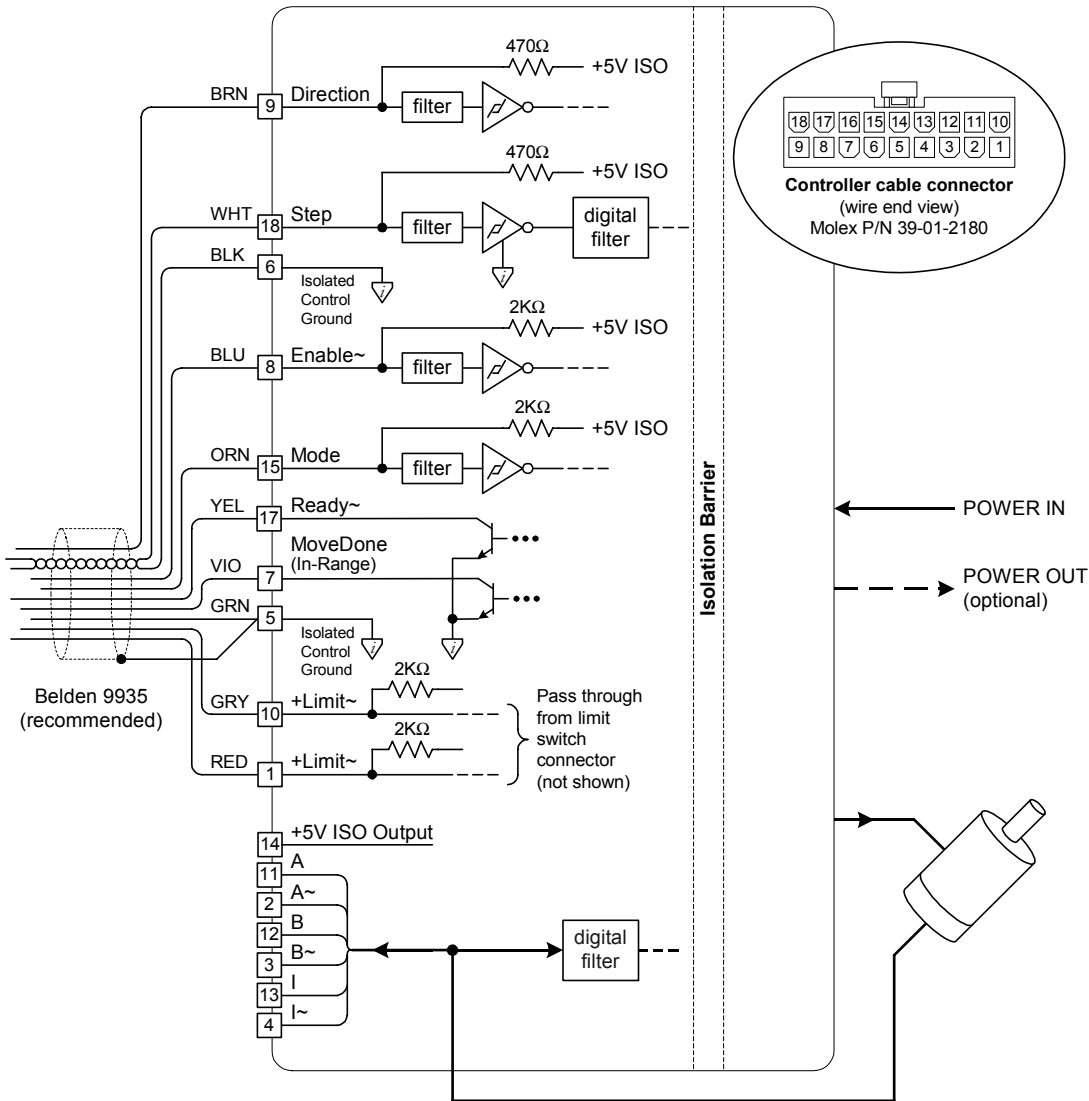

Interfacing to the SSt-1500 for an all-digital system.

Note on making reliable cables: Some of the diagrams in this section show multiple wires connected to one crimp pin (generally the isolated control ground, pin 5). When doing this, it is helpful to crimp only one wire into the pin (or, at most, two wires) and then solder additional wires to that. Don't attempt to crimp more than two wires to one pin-it will be an unreliable connection.

USING THE SST-CC CABLE

The SSt-1500 evaluation kit includes an SSt-CC cable which makes it easy to hook up your indexer/controller to SSt servo drive. This cable is provided as a “universal donor”, i.e. it contains *all* signals for hooking up an analog output servo controller or a digital stepping controller (indexer). If many systems are to be duplicated a smaller, less expensive cable with fewer signals and connections can be fabricated as shown above at the beginning of this section.

All of the connections necessary to use the SSt-CC are detailed below. The diagram also explains how to use the SSt servo drive’s isolated grounds to their best advantage and is consistent with the preceding “Golden Rules”. PLEASE FOLLOW THESE RECOMMENDATIONS.

CONNECTING A MOTOR TO THE SST-1500

Important notes about connecting and disconnecting motors:

1. Before connecting or disconnecting any motor, always make sure that is disabled (not necessarily powered down)
2. If the configuration of the drive is unknown, or if you connect a different motor to the drive than that which was previously connected, the proper configuration must be loaded before enabling the drive.
3. After connecting a motor to your SSt servo drive, you must always reset the drive using the Reset Drive command under the Setup menu (cycling power off and on also resets the drive). You must do this before you enable the drive.

DRIVE-MOTOR CABLE FOR TEKNIC M-1726, M-2330, M2348, M3437 AND M3450 MOTORS

Teknic M-1726, M-2330, M2348, M-3437 and M-3450 motors come pre-configured with a standard "pigtail" and 16 pin Molex Minifit type connector. The Motor connector on the SSt-1500 is a 20 pin Molex Minifit type. In order to connect any of these motors to the SSt-1500, the cable shown below should be constructed.

Sources are specified for both the connectors and the raw cable required in the diagram below. The Belden products are economical flexible cable stocks with excellent electrical properties, but are not rated as to their flex life. They are an excellent choice for applications which do not require the drive-motor cable to flex. The Olflex cable product has been specifically designed and tested to withstand millions of cycles of flexing and should be used in cable track applications.

Each SSt servo drive evaluation kit contains a 10-foot cable wired as shown below (P/N: SSt-MC).

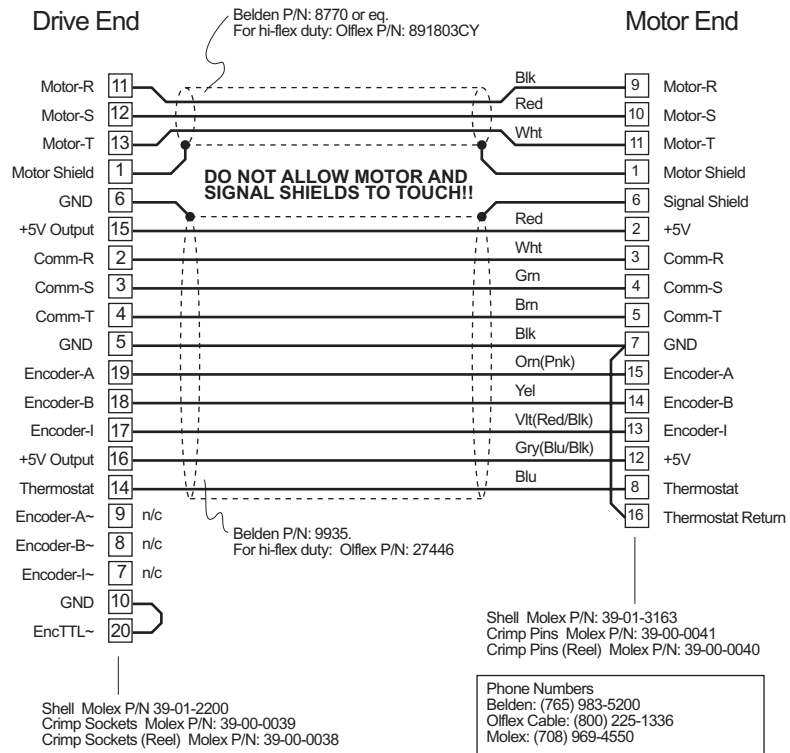

Constructing a motor-drive cable (such as Teknic's SSt-MC cable) is a simple task which requires only readily available "off-the-shelf" wire and connectors.

Note: The cable used within the SSt-1726, 2330, 2348, 3437 and 3450 motor pigtailed non rated for continuous flexing, so it is important to strain relieve it such that it does not flex repeatedly in your application.

CONTROLLER SIGNALLING DETAILS

STEP & DIRECTION SIGNALS (PINS 18 & 9);

SSt servo drive can connect directly to any stepper motor indexer or pulse source using industry-standard Step and Direction signals. The Step and Direction signals from the indexer can be open-collector or TTL-level driven signals. Shielded wiring should be used for these signals with shielded twisted pair wiring being preferred for the Step input.

Because SSt servo drive responds to Step and Direction signals as fast as 2.0 MHz (2 Million steps/second) they will also respond to fast pulses that can be generated by noise as well. The most common source of spurious Step and Direction pulses is conducted noise due to several digital signals sharing a ground path with the Step and Direction signals, therefore:

Care should be taken to ground the twisted pair wiring for the Step and Direction signals directly at the controller/indexer's card output connector, not a central system frame ground or other ground point. Using a "Breakout Board" can also be problematic because the cable

between the controller/indexer and the "Breakout Board" typically shares the SSt's isolated control ground with other digital signals which can induce noise into the Step and Direction signals.

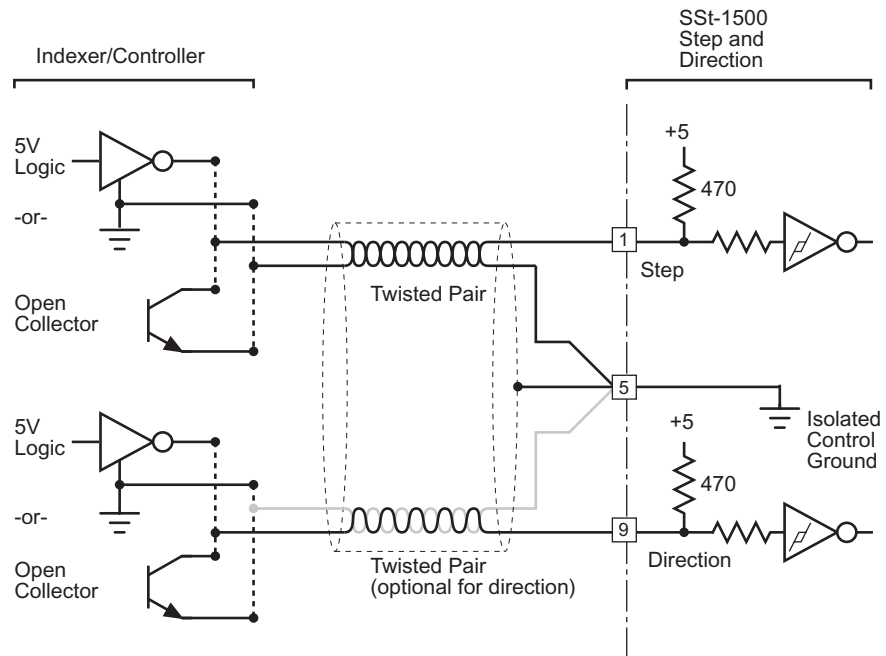

Step & Direction Input Wiring

If your system exhibits any "walking", drifting or repeatability problems it is likely that the Step and Direction wiring is at fault.

STEP POLARITY & TIMING

SSt servo drives will be commanded to rotate one step when the Step line makes a transition from a low level to a high level (known as "positive edge triggered"). The required timing for both the Step and Direction signals is shown below.

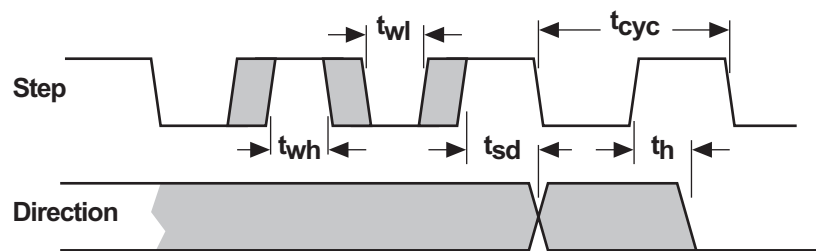

Step and Direction Timing Wiring

The minimum time for t_{wl} , t_{wh} , t_{sd} , and t_h is 400nS. The minimum time for t_{cyc} is 800nS. There is no maximum limit for any of these timing variables.

If you wish, you can reduce t_{wl} , t_{wh} , t_{sd} , and t_h to 200nS and t_{cyc} to 500nS by turning off the command input digital filter. This will allow you to operate with input signals as fast as 2MHz with some degradation in noise immunity. (Contact Teknic for details on how to do this)

DIRECTION POLARITY WIRING.

With a standard motor cable the Direction line will have the following effect: With Direction at a high level, the motor will rotate clockwise (when viewing the shaft while facing the drive end of the motor) for each pulse of the Step line, and the internal position register (which is displayed by SSt-QuickSet's™ Status window) will decrement for each step pulse. When the Direction line is at a low level the motor will rotate counter-clockwise and the SSt servo drive's internal position register will increment for each pulse of the Step line.

You can reverse the natural direction of SSt servo drive by clicking the Reverse checkbox in SSt-QuickSet's Inputs and Limits window.

INPUT CONTROL SIGNALS

All of the logic control inputs: Enable~, Mode, Limit+ and Limit- on SSt servo drive have the identical input circuit shown below. This circuit can be driven by TTL & 5V CMOS logic outputs, open collector outputs, optoisolator outputs from your indexer (controller), or a simple switch or relay. Wiring for interfacing to each of these inputs is shown below.

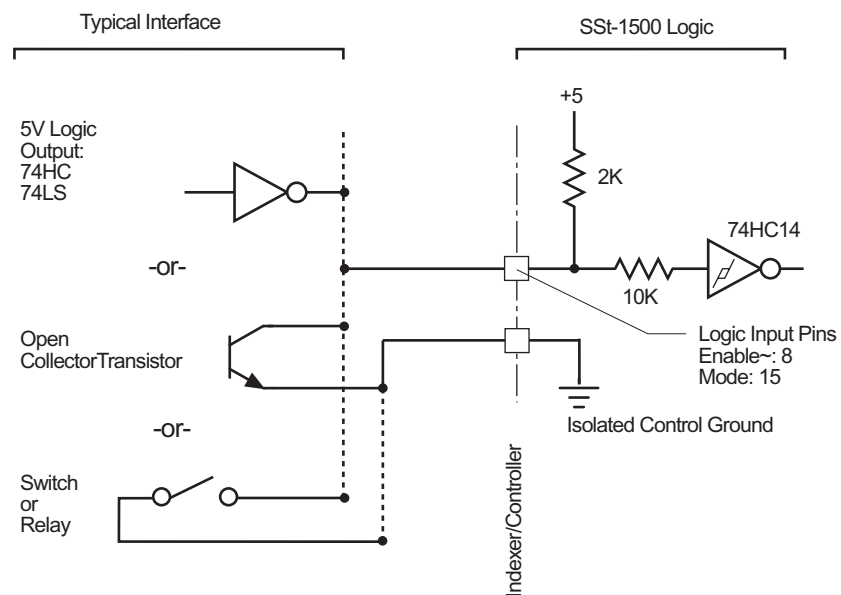

SSt logic input wiring

ENABLE~ (PIN 8)

The Enable~ input signal enables the SSt servo drive, allowing power to be applied to the motor under control. A low TTL level (or open collector output on) should be used to assert the Enable~ input. The function of this signal is nearly identical to a stepper motor drive's enable signal sometimes marked as "AWO" (All Windings Off) on popular stepper drives.

If you're not using a Teknic-supplied SSt-CC controller cable which has a switch on the Enable~ line, you should install a simple switch in series with the Enable~ pin (pin 8 on the Controller connector) and your indexer. This will allow for a fast and easy way to disable SSt servo drive, without the intervention of software. The tuning process requires

disabling the drive at times, and the switch can also be used as a "kill" switch, if necessary. Toggling the switch will also clear any drive protection shutdowns that might occur. (De-asserting the Enable~ line clears the Ready condition. SSt servo drive will then be fully operational when the Enable~ line is re-asserted.)

MODE (PIN 15)

The Mode signal toggles the drive between two operating modes.

On the SSt-1500-AXX (advanced positioning) setting the Mode line low will put the drive into a torque/force limit mode that will limit torque/force in the positive direction, negative direction or both. The fold-back torque/force limit and direction is set using SSt-QuickSet's "Inputs and Limits" window. This mode is useful for clamping objects or allowing the axis to become compliant.

On the SSt 1500-PXX (programmable analog) the Mode line switches the drive between velocity control mode and torque control mode. When this signal is grounded, SSt 1500-PXX will be in torque control mode; when driven to a high level, or left open, the drive will be in velocity mode. The state of the Mode signal can be changed at any time and the SSt-1500-PXX will respond by changing the control mode within 120µS. If you want to switch between velocity and torque modes "on the fly" you should hook it to an I/O line from your indexer/controller and run it under program control. Otherwise this input should be left disconnected for velocity control or connected directly to ground for torque control.

LIMIT- AND LIMIT+ (PINS 1, 10)

Limit switch inputs are provided to safely shutdown of the motor in case preset travel restrictions are exceeded. Inputs are provided to operate with normally-closed switches only. Normally-closed switches are used so the motor will not function if the limit switch connector is inadvertently removed or the circuit is interrupted elsewhere in the machine.

The limit switch inputs can operate in two distinct modes. The first will limit torque in the direction of the limit switch. This is the traditional torque limit switch mode used on most servo systems. The second, more popular mode, is position limit switch mode that will use the available power of the SSt-1500 to stop the axis at the limit switch position. This mode can also be used for precise axis homing when used with an optical switch.

The limit switch inputs are routed to the indexer/controller connector so the limit information can be relayed to the indexer (controller), if desired, without any need for a tee in the wiring harness.

For the purpose of testing, or if limit switches are not used it will be necessary to fabricate a limit switch "cheater" plug as shown below to defeat the limit inputs. Such a plug is provided with each SSt servo drive evaluation kit (P/N:SSt-CP).

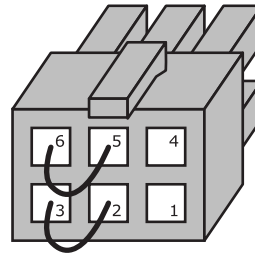

Limit Switch Cheater Plug

Courtesy power pins are provided on the SSt servo drive's limit input connector to run optical interrupter switches. These switches are popular in OEM applications because they are inexpensive, ultra-reliable and non-contact. They are fail-safe when used with the SSt servo drive—the axis will be disabled if the illuminating LED fails or the sensor becomes obscured by dirt or debris. Alternately, Hall-effect "vane" sensor switches can be used in the same manner as the optical switches. The Hall-effect switches are immune to dirt but have poorer position repeatability than the optical interrupter switches.

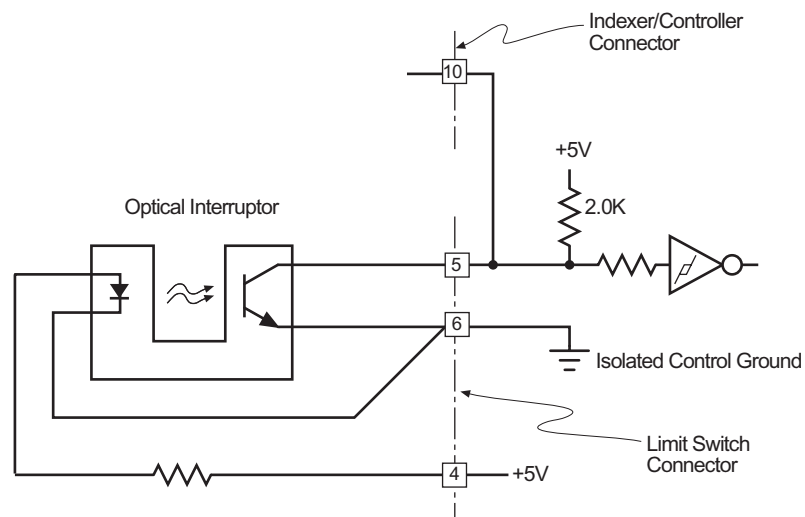

Using Optical Interrupter Limit Switches (+Limit input pin numbers shown)

OUTPUT CONTROL SIGNALS

Both the MoveDone[InRange~] and Ready~ circuits are open collector outputs without pull-up resistors, they are rated for switching non-inductive loads up to 40V at a maximum of 100mA. These outputs are compatible with TTL and CMOS logic inputs when a pull-up resistor is used. They can also be used directly to switch non-inductive loads such as lamps or LEDs. If you wish to use these outputs with an inductive load such as a relay coil, a snubber diode across the winding must be connected, as shown below, across the coil to prevent the inductive spike from damaging the output transistor. Typical interconnection wiring for these outputs is shown below.

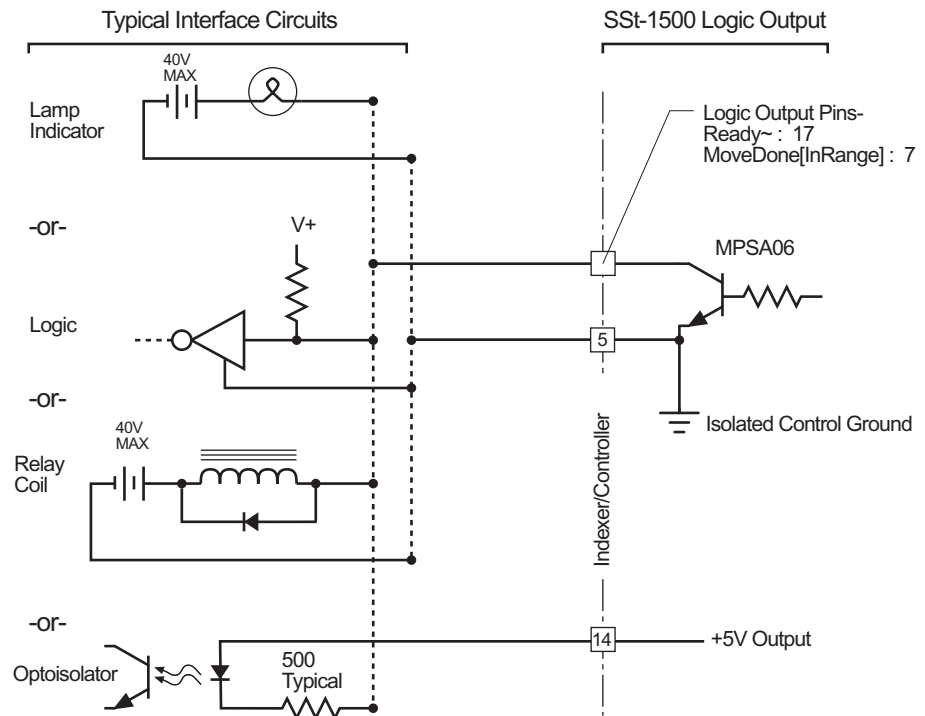

SSt logic output wiring can be used to run a wide variety of devices.

READY~ (PIN 17) [SHUTDOWN~ ON SST-1500-PXX]

The Ready~ signal is an open collector output which is asserted (turned on) when the SSt servo drive is ready to respond. This signal is asserted whether the SSt servo drive has been enabled or not. The Ready~ signal when asserted, should be interpreted by the attached controller as “ready to enable —or— enabled and ready to run”

The Ready~ line is de-asserted and the SSt servo drive is disabled immediately upon the occurrence of any protection shutdown event. The SSt’s protection shutdown events include: over current, over voltage, step input overspeed, output-time alarm, tracking error alarm, RMS current limit exceeded, motor thermal overload or drive thermal overload.

On the SSt-1500PXX servo drive pin 17 is interpreted as “Shutdown~” and is asserted (pulled low) when drive safety shutdown has occurs. It is not asserted during drive initializing after power-up (so your control program should wait 4 seconds after the application of power and check that Shutdown~ is not asserted before sending a command to the SSt-servo drive.)

MOVEDONE[INRANGE~] (PIN 7)

The MoveDone[InRange~] signal is operative only when an SSt-1500 is in positioning mode. It can be set in one of two operational modes: MoveDone or In Range.

The Move Done mode is popular in point-to-point applications. When this open collector output is configured to operate in MoveDone mode it will transition to a low state upon the first pulse of a digital command and then to a high state (de-asserted) when the move is

complete. The state of the MoveDone line is calculated every servo cycle and is set true when the axis has settled within a pre-programmed window for a pre-programmed amount of time. Fuzzy logic is also employed to prevent false triggering of the MoveDone signal if an axis is ringing at the end of a move.

The InRange~ mode is popular for a path following applications (e.g. CNC cutting). In the InRange~ mode this signal acts as a positive-true, open collector output signal which is pulled low when the following error (the instantaneous difference between the commanded position and the actual position) of the SSt is outside a pre-programmed window. It is typically used as a following-error flag to alert your controller/indexer to reduce the feed-rate (or change the cutting tool) in contouring applications.

Because it is de-asserted when true, InRange~ signals from several SSt servo drives can be connected together to form a "wired-OR" indication that one or more of the axis are not "in range". If *any* SSt drive is out of range, this wired-OR line will be asserted (pulled low). This wired-OR signal can then be used as a global "out of range" input to your controller (using only one input on your controller for to monitor all the axis involved in the contouring application.) Note: This can only be done if you have connected the isolated control ground (GND) on each of the drives to a central ground point at your controller/indexer.

The operation of the MoveDone[InRange~] signal is configured using SSt-QuickSet's Inputs and Limits window.

USING THE SST-1500-PXX WITH A SERVO CONTROLLER;

An analog input is provided on SSt-1500-PXXX models to facilitate its use as an analog input servo drive (also sometimes referred to as a servo amplifier). The analog input responds to $\pm 10V$ full scale input signal which can be used to control torque or velocity. When the analog signal is used to control velocity the maximum speed which corresponds to a full 10V input can be programmed using SSt-QuickSet™.

This analog input is a differential-type circuit to reduce the effect of conducted or induced common-mode noise. For optimum noise immunity shielded twisted pair cable wiring should be used as shown below.

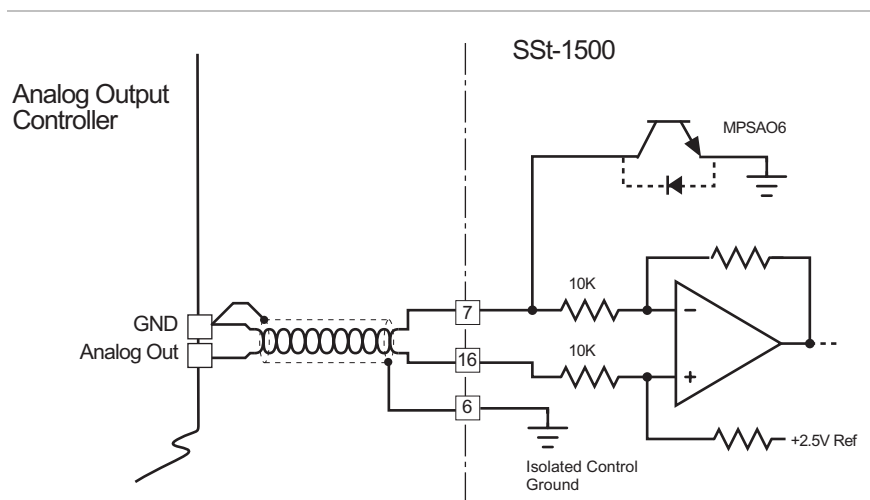

Analog Command Input Wiring

ENCODER INTERFACE

Incremental encoders are available with one of two types of output drive circuits: Single-ended or differential. Single-ended outputs are usually TTL driven lines or open collector outputs. Differential output circuits have two driven balanced output lines for each signal.

SINGLE-ENDED ENCODERS

The SSt-1726, 2330, 2348, 3437 and 3450 motors incorporate a single-ended encoder for position/velocity feedback. The particular encoders used on these Teknic motors have rugged Mylar® optical disks and fault-tolerant read sensors for high reliability.

Encoders with single-ended outputs are the most common and least expensive type of encoder. Properly terminated and shielded, this signaling method provides excellent fidelity for cable runs up to 25 feet. In some industrial circles, however, single-ended encoders have an undeserved reputation as being noise susceptible. Yet they are no more noise susceptible than any other TTL digital device. Most problems occur with single-ended encoder signaling because of poor termination, shielding or ground loops. If you follow the recommendations for cable wiring shown in this manual, you will be very unlikely to encounter any problems.

To configure the SSt servo drive for use with a single-ended encoder connect pin 20 to GND (pin 10). (This has already been done in a Teknic SSt-MC cable.) The circuit shown in the diagram below will then be used to receive signals from the encoder. The diagram below also shows typical encoder cabling. Take care to construct this cabling literally and do not connect the cable shield or the encoder ground (isolated control ground) to the motor or chassis, as this is likely to induce noise.

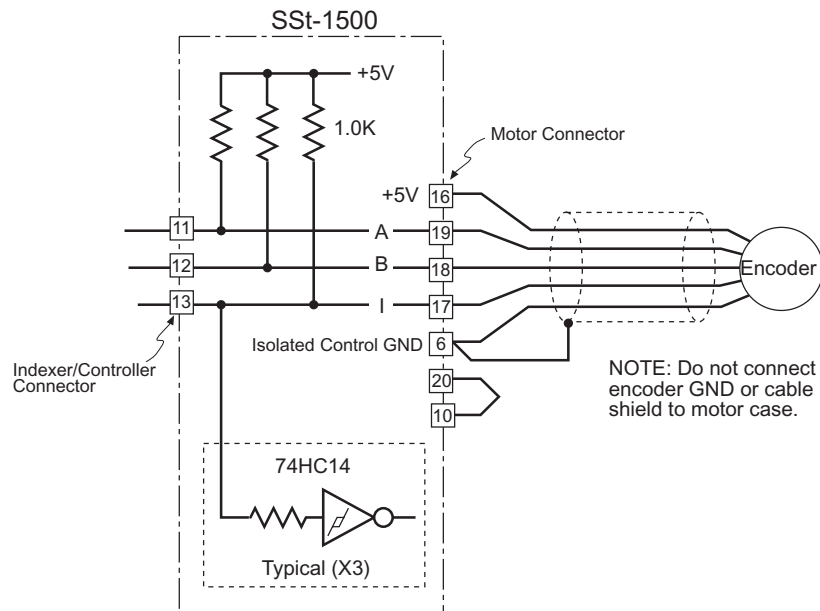

Single-Ended Encoder Wiring. (Used on Teknic M-1726, 2330, 2348, 3237 and 3450 motors.)

NOTE: Leave A~, B~ and I~ (pins 2, 3 and 4 on the SSt-1500's controller connector *disconnected* when using a motor with a single-ended encoder!

DIFFERENTIAL ENCODERS

SSt-3462, 3471, 497P and 497T motors have encoders with differentially driven output signals.

Differential encoders have balanced (symmetrical, inverted) driven outputs intended to drive terminated, twisted pair transmission lines. This type of signaling method has high noise immunity and will function well when high common-mode noise would otherwise be a problem. They are also well suited to signals in excess of 200kHz and long cable runs.

To configure SSt servo drive for use with a differential encoder leave pin 20 open (disconnected) on the Motor connector. The circuit shown in the diagram below will then be used to receive signals from the encoder. The diagram below also shows typical encoder cabling. Take care to construct this cabling literally and do not connect the cable shield or the encoder ground (isolated control ground).

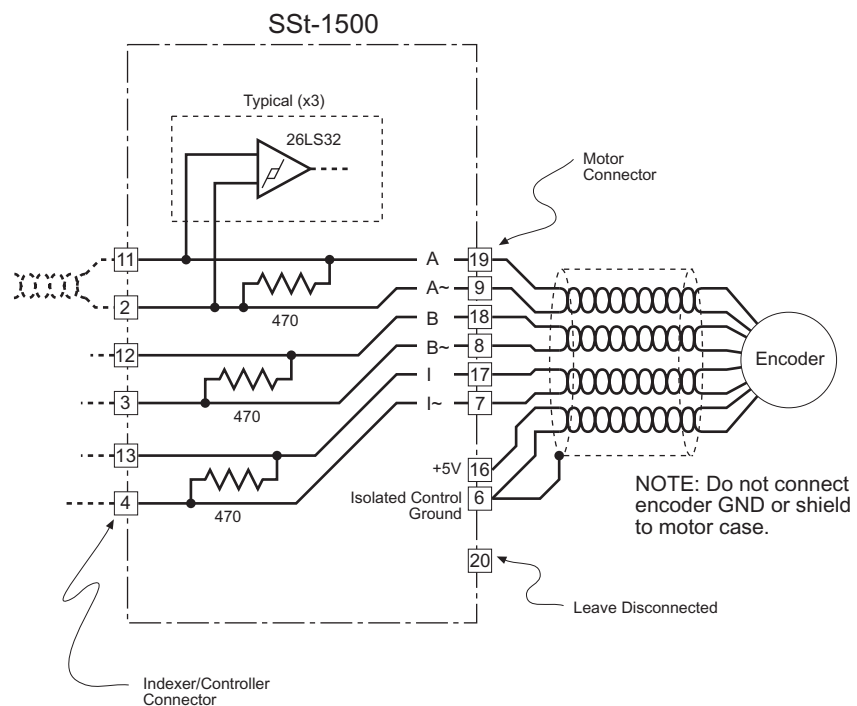

Differential Encoder Wiring

ENCODER TERMINATION RESISTORS))

The SSt-1500 can accept encoder signals to 500kHz (2MHz count rate after quadrature multiplication), if your application calls for using encoder signals above 200kHz with long cable runs you should consider using termination resistors for maximum noise immunity and signal fidelity. Proper termination matches the termination resistor value with the characteristic impedance of the wiring used. Typical twisted pair cable has a characteristic impedance (R_c) of 100 ohms to 200 ohms. (Your cable manufacturer should be able to tell you the characteristic impedance of your twisted pair cable.)

The SSt-1500 Plus has 470 ohm termination resistors on each balanced pair of encoder input lines. This is typically a slight mismatch with popular twisted pair cables. Although in general this is not

optimum, it was done specifically so that if the encoder lines continue on to an indexer/controller, they can be terminated there as well without overloading the encoder's drivers. If you are not routing the encoder signal to your indexer/controller you can precisely match the termination resistance to your cable by adding external termination resistors at the SSt-1500 end of the motor-encoder cable. The value of these resistors should be $470R_c/[470-R_c]$ ohms. Alternately, if you are routing the encoder signals to your indexer/controller, then termination resistors should be installed at the controller equal to R_c .

POWER SUPPLY

The SSt servo drive runs off unregulated DC voltages from 24 to 75 volts. A bulk, linear supply (essentially a transformer, bridge rectifier and capacitor) with a large output capacitance (for minimum droop at high current draw) is best. Aside from being inexpensive, this kind of supply can source large peak currents relative to its RMS rating. This is exactly what you want for powering a high-performance servo system. Switching power supplies have current limiting to protect themselves in case of an overload. When high current is drawn from the supply, the voltage drops until the current ceases. This also occurs when using a ferroresonant supply beyond its rated current. This will cause reduced performance at best, and, if the voltage drops below 24 volts, may cause SSt servo drive to cycle off and on.

Each SSt-1500 has two identical bussed power connectors, and the power circuitry is electrically isolated from both isolated control ground (GND) and the chassis. This allows power to be daisy-chained from one SSt-1500 to the next for a minimized wiring harness without fear of creating ground loops in the system. The power connectors are rated at 15A RMS. If the RMS current for a group of the SSt servo drive's is less than 15A (see the next section on Power Supply Current Requirements), they can safely be daisy-chained. Otherwise traditional "star" power distribution is required. In typical incremental positioning applications, at least five the SSt servo drive's can be wired in a daisy-chained manner.

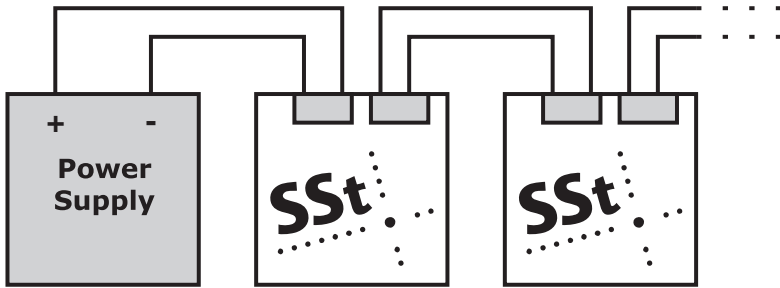

"Daisy Chain" Power Distribution

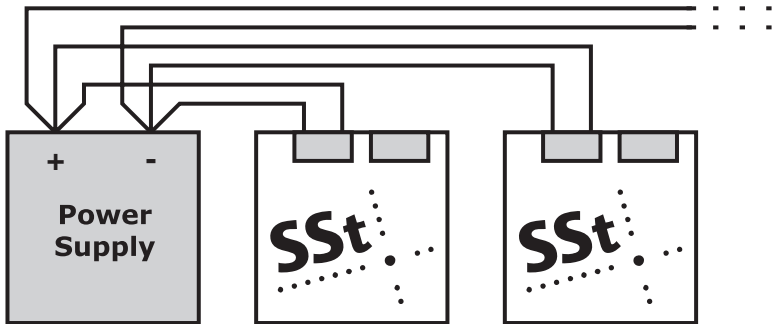

"Star" Power Distribution

Power Wiring Options

The power wiring should be constructed with 18AWG wire or lower gauge (larger) wire. See the table on page 8 for recommended wire gauges. The AMP Universal Mate-N-Lock power connectors will accept wire as large as 10AWG. The wire should be sized to limit the voltage drop to less than 2V under peak current demand.

If you are using your own power supply (without an AMP Universal Mate-N-Lock power connector), you can simply cut off one of the connectors on an SSt-PC power cable and connect the white wire to the positive output terminal of your supply and the black wire to the negative terminal.

Caution: Use care when connecting to your power supply. Reversing the supply polarity can damage your drive. Polarity is shown below for use in making your own cables.

Power Connector on Drive (not cable connector)

AMP Universal Mate-N-Lock, mates with

P/N 1-480-698-0

(view shown looking *into* connector at SSt drive)

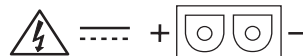

In order to get the maximum utilization from an SSt servo drive, a supply that can deliver high peak currents is required. This is best provided by a "bulk" unregulated supply: essentially a transformer, rectifier and a large capacitor. Most switching supplies are ill-suited to servo applications for two reasons: (1) they usually have identical peak and continuous current ratings, forcing you to purchase a large but under-worked supply and (2) when motors are de-accelerated they pump

current back into the supply. Most switchers are not built to accept this and may cycle, shutdown or, in the worst case, fail.

POWER SUPPLY CURRENT REQUIREMENTS

To properly size a power supply to work with your SSt servo drive system you will need to calculate the maximum peak current and RMS current for each SSt servo drive in your system. The peak rating of your supply should then be the sum of all of the individual the SSt servo drive's maximum peak currents. The continuous rating of your supply should be the sum of all the individual the SSt servo drive's maximum RMS currents.

The peak and RMS current drawn by an SSt-1500 are less than the peak and RMS current supplied to the motor. This is not magic. The SSt servo drive's output amplifier acts as a very efficient power switching converter. The output amplifier ensures that the input power from the supply is equivalent to the power supplied to the motor. Because the power supply voltage is greater than the voltage supplied to the motor windings, the current drawn from the supply is less than that supplied to the motor. (This conserves power which is equal to Volts times Amperes.)

SIZING A SUPPLY QUICKLY

The following procedures carefully calculate the supply requirements for an SSt-1500 operating under various loading from an arbitrary supply voltage with any motor. In actual practice these calculations may be difficult to apply due to varying duty cycles, loads and machine sequences. Often the best way to size a supply is to run your machine while measuring the RMS current between the bridge rectifier and transformer with the RMS filter in your amp meter set to 10 seconds or more. The transformer is then sized so that its RMS limit is not exceeded.

If you want to avoid these calculations and measurements you are operating the SSt-1500 from a 75V supply using Teknic supplied motors, the worst case RMS current draw is 3A and the worst case peak current is 12A. This assumes that you are operating the motors within their rated torque-speed curves, for an incremental positioning application. These numbers are conservative. For most incremental positioning applications, the RMS current will be substantially less than 3A and the peak current can be less than 12A if the motor is operated below peak speed. Typically the RMS current drawn by a point-to point axis is 1.5A.

CALCULATING PEAK CURRENT REQUIREMENT

To calculate peak supply current demand from any SSt servo drive you need to know three things: [1] the supply voltage (V_s), [2] the phase to phase resistance of the motor (R_t), and [3] the peak shaft power in Watts available from the motor when the SSt-1500 is supplied by V_s (S_{pmax}). The peak current demand, I_{smax} , for brushless motors is then:

$$I_{smax} = [0.75I_p^2R_t + S_{pmax}]/V_s,$$

where I_p for an SSt-1500 is 23 Amperes.

Peak shaft power of a vector driven brushless motor is highly dependent upon the inductance of the motor, the number of motor poles, supply voltage, drive peak current and the winding resistance. It cannot, in

general, be easily calculated. Worst case peak shaft power values have been pre-calculated and verified for Teknic standard motors when operated with a 75V supply and you should use these in figures your calculations. If you are using a custom motor or a different supply voltage, contact Teknic for an estimate of the peak shaft power that will be produced using an SST-1500 drive.

PEAK CURRENT WHEN USING LESS THAN FULL OUTPUT

If you are planning on using the motor at a peak speed below the speed at which maximum power is produced and/or if you plan to limit the torque to some value (T_p) less than the peak rated torque¹ (T_r), then calculate S_{pmax} and I_p as follows for use in the I_{smax} formula above:

$$S_{pmax} = T_p V_{max} / 1352, \text{ and}$$

$$I_p = 23T_p / T_r$$

where V_{max} is the maximum speed in RPM.

CALCULATING RMS CURRENT REQUIREMENT

The RMS current demand from the supply is dependent upon the application type. Two sets of calculations are provided below. If the application is for incremental positioning, as in a "pick and place" machine, then calculation method (1) or (1a.) should be used. If the application is a continuous velocity type, such as running a conveyor, then calculation method (2.) should be used².

1. INCREMENTAL POSITIONING APPLICATIONS

If the application is incremental positioning, then we assume that the torque is being used primarily to accelerate the motor and load from zero to a maximum speed and then to decelerate it back to zero speed again.

We can also assume that the current used to decelerate the load is not drawn from the supply (part of it is actually pumped back into the supply during deceleration). Given this assumption, the maximum RMS current demand from an SST-1500 is:

$$I_{RMS} = \sqrt{\frac{tdc \left[\left(S_{pmax} + \frac{3}{4} I_p^2 R_t \right)^3 - \left(\frac{3}{4} I_p^2 R_t \right)^3 \right]}{3V_s^2 S_{pmax}}}$$

where tdc is the torque duty cycle defined as:

$$tdc \equiv \frac{\text{torque on time}}{\text{torque on time} + \text{torque off time}}$$

¹ This can be accomplished explicitly by setting a torque limit parameter within the SST-1500 using SST-QuickSet™ or by reducing the acceleration demand so less torque is required.

² CNC cutting type applications usually are a hybrid of both incremental positioning and constant velocity applications so the higher of the two calculated RMS current figures should be used to determine the worst case maximum RMS current.

Torque on time should not be confused with the running time of the motor. It is the time that torque is being used to accelerate or decelerate the motor and can be a small portion of the running time when trapezoidal velocity move profiles are used. (It is equivalent to the motor running time when only triangular velocity type move profiles are used.)

tdc can be a maximum of 0.15 for an SSt-1500 that uses full output torque to accelerate and decelerate the load (at this duty cycle the output current is 9A RMS which is the rated limit of the Motor connector). You should attempt to estimate tdc for your application if possible, otherwise use 0.15 as a conservative estimate if you plan to use the full output torque capability for acceleration (although this will probably cause you to over-specify your supply requirements).

1A. INCREMENTAL POSITIONING WITH REDUCED OUTPUT

If you are planning on using the motor at a peak speed below the speed at which maximum power is produced and/or if you plan to limit the torque to some value (T_p) less than the peak rated torque (T_r), then calculate S_{pmax} , I_p and tdc_{max} as follows:

$$S_{pmax} = T_p V_{max} / 1352,$$

$$I_p = 23T_p / T_r, \text{ and}$$

$$tdc_{max} = \min \left[1, \left(\frac{9T_r}{23T_p} \right)^2 \right]$$

where V_{max} is the maximum speed in RPM.

Now use these I_p , and S_{pmax} values and your estimate of tdc to calculate IRMS using the formula above. If you can't estimate tdc in your application then use the tdc_{max} calculated above as a conservative estimate (although this will probably cause you to over-specify your supply requirements).

2. CONTINUOUS VELOCITY APPLICATIONS

If the application is for a continuous velocity application such as running a conveyor at some constant speed (V_{cont}) then we assume that the drag load (T_d) is predominant. For these applications you can calculate the RMS supply current required based upon the continuous output power as follows:

$$I_{RMS} = [0.75I_c 2R_t + S_{pcont}] / V_s,$$

where:

$$S_{pcont} = T_d V_{cont} / 1352, \text{ and}$$

$$I_c = 23T_d / T_r$$

DIAGNOSTIC CONNECTOR: REAL-TIME MONITOR PORT AND THE SST-QUICKSET™ CONFIGURATION CONFIGURATION

REAL-TIME MONITOR PORT

The SSt servo drive includes an Real-time Monitor port (analog monitor output) for viewing system variables on an oscilloscope or for use with a data logger. This Real-time port is typically viewed with a standard oscilloscope and provides a wealth of analytical information on SSt servo drive and the mechanics to which it is connected.

A great benefit of the port's real-time nature is that you can use your oscilloscope to look at SSt servo variables while viewing other non-servo signals in your machine to verify controller timing and find software bugs.

Actual velocity, commanded velocity, velocity error, tracking error, commanded torque as well as other variables can be displayed with ease. The Monitor output is configured using SSt-QuickSet™ as described in the SSt-QuickSet™ on-line Help.

The monitor output is a 0.5-4.5 volt signal centered around a 2.5 volt "zero" reference. A 2.5 volt DC reference signal is also provided at the diagnostic connector (pin 5) for use with instruments that have differential inputs.

RS-232 CONFIGURATION PORT

An RS-232 interface is provided for configuring SSt servo drive using SSt-QuickSet™ software. There is no need to install this interface permanently.

RS-232 handshaking signals are not provided or used by the SSt-1500. The Rx and Tx signals are fully RS-232 compatible. The communication format is 8 bit, asynchronous, half duplex with a single start bit, a single stop bit and no parity. It is recommended that the DCE CD, RI, DSR, and CTS input signals be connected to the DCE DTR signal to prevent noise from affecting the operation of the host computer.

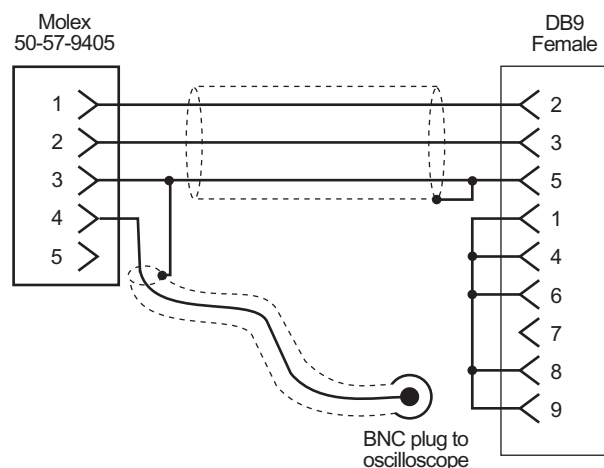

Typical Diagnostic/Configuration Cable (such as the Teknic SSt-DC)

MISCELLANEOUS ELECTRICAL INFORMATION

TESTING WITH A MOTOR THERMOSTAT

While integrating the SSt servo drive motor into your machine, you might want to attach a normally-open thermostat that will trip when the case of the motor exceeds 80 deg. C. It is unlikely, under normal usage, that this thermostat will trip because of the SSt servo drives built-in RMS torque monitoring. However, in some high ambient temperature applications, the motor case may exceed this temperature and the SSt servo drive should be disabled. If this occurs during your integration testing you should consider one of the following solutions: (1) improving the heat sinking path connected to the motor by increasing bracket size, etc. (2) providing forced convection cooling with a fan (3) increasing the size of the motor, and/or (4) reducing the torque requirements by lightening the mechanism, lowering the mechanism's duty cycle or throttling back the acceleration demand.

Very rarely is a thermostat required once your machine goes into production. However, if you expect the ambient temperature in the vicinity of the motor to vary widely you might want to consider using a permanent thermostat to protect the motor.

FUSE & INDICATOR

Each SSt-1500 has a fuse to protect the internal circuits and your power wiring from catastrophic failures. The fuse is a 3AG 10A thermal delay type, which can be user replaced. The fuse can blow under certain abnormal operating conditions or a blown fuse can indicate that the SSt-1500 has been damaged.

A red LED on the front panel illuminates if the fuse fails. This LED blinks on the application of power. The fuse indicator LED will also cycle on and off if an internal or external short on the +5V output from the SSt servo drive occurs. If cycling occurs, check for shorts on your limit switch, encoder and commutation sensor wiring.

USING A CUSTOM MOTOR

The SSt-1500 can be used with any three-phase permanent magnet brushless motor with an encoder, including linear motors, or any brush motor with an encoder. For specifics on how to wire and set up an SSt servo drive for use with a custom motor and encoder, call Teknic.

MECHANICAL INSTALLATION

Mechanical drawings for the SSt-1500 (with and without the case option), and for Teknic motors are shown on the following pages. Mechanical mounting data are provided within each drawing.

Any of the following outline drawings can be downloaded from Teknic's web site in native AutoCad™ .DWG format. Simply look for a download link on the motor specification page for the particular model you are interested in.

SST-1500-ACX MOUNTING (DRIVE WITH CASE OPTION)

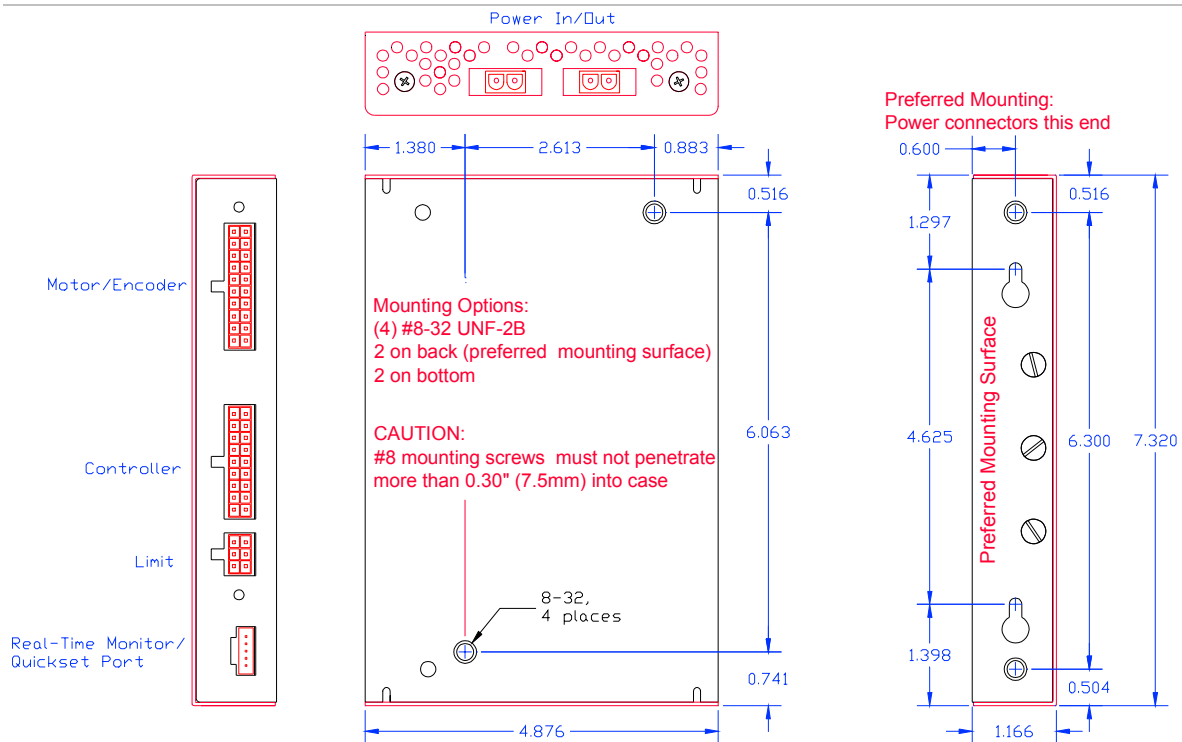

For best heat dissipation, maximum continuous output power, and highest reliability, we recommend mounting the drive in the vertical orientation (like a book on a bookshelf). by the narrow back side (the side with the keyhole slots) into a thermally conductive material (e.g.: aluminum machine frame). Other mounting configurations will generally work, but are less desirable.

SST-1500-ALx MOUNTING (DRIVE ON "L" BRACKET)

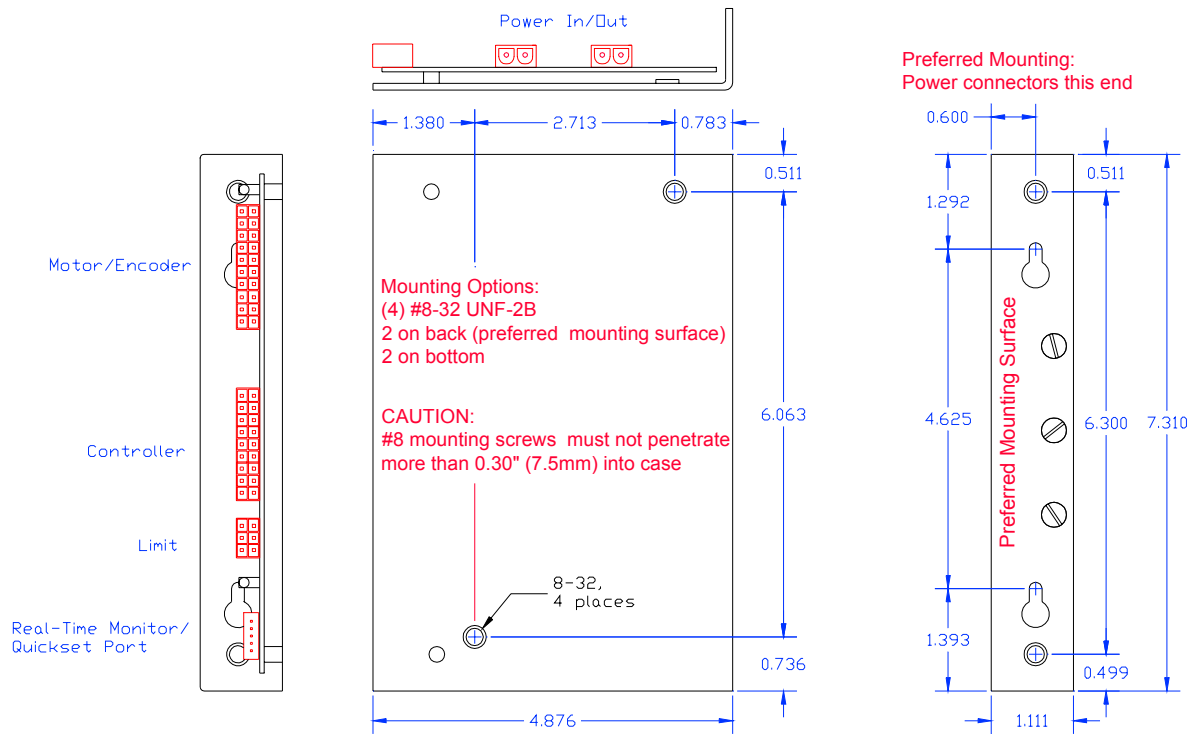

For best heat dissipation, maximum continuous output power, and highest reliability, we recommend mounting the drive in the vertical orientation (like a book on a bookshelf). by the narrow back side (the side with the keyhole slots) into a thermally conductive material (e.g.: aluminum machine frame). Other mounting configurations will generally work, but are less desirable.

MOTOR OUTLINE DRAWINGS:

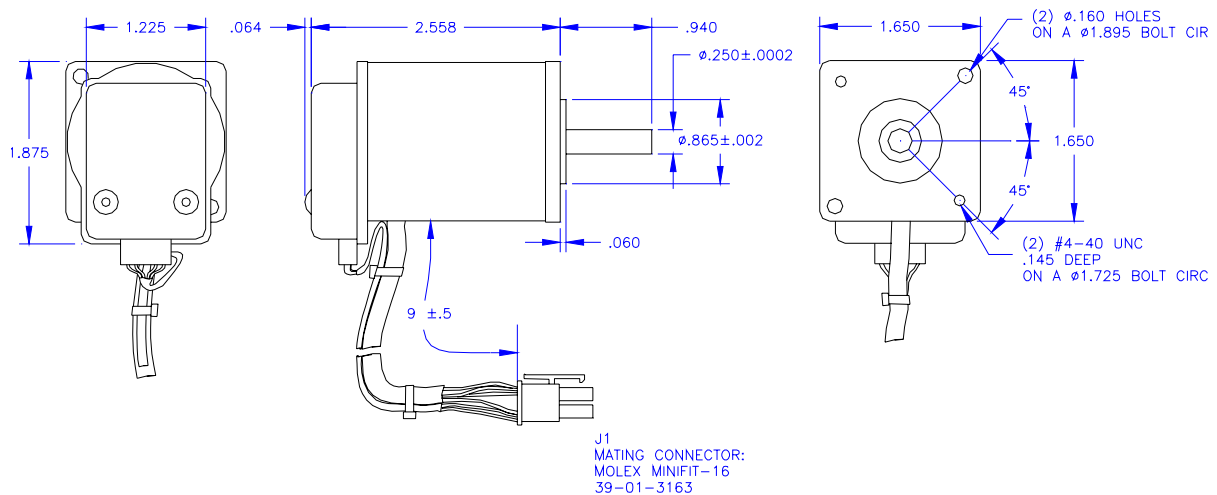

M-1726-FX: 4,000 counts/rev. with NEMA flange

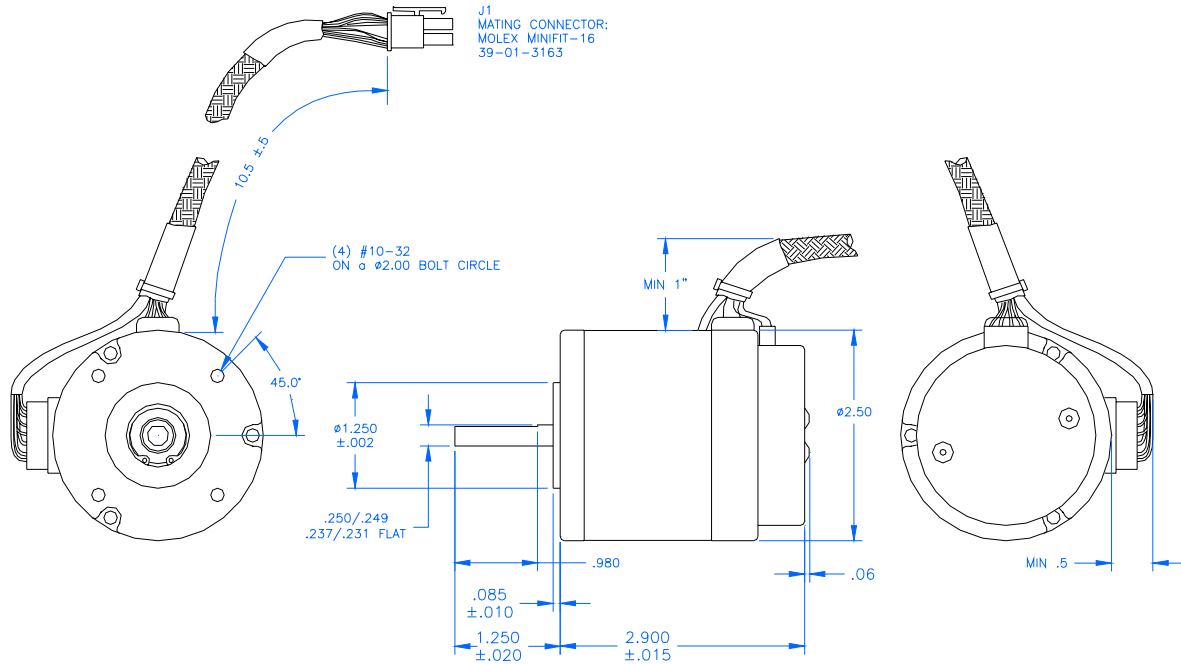

M-2330-XX: 4,000 counts/rev. without NEMA flange

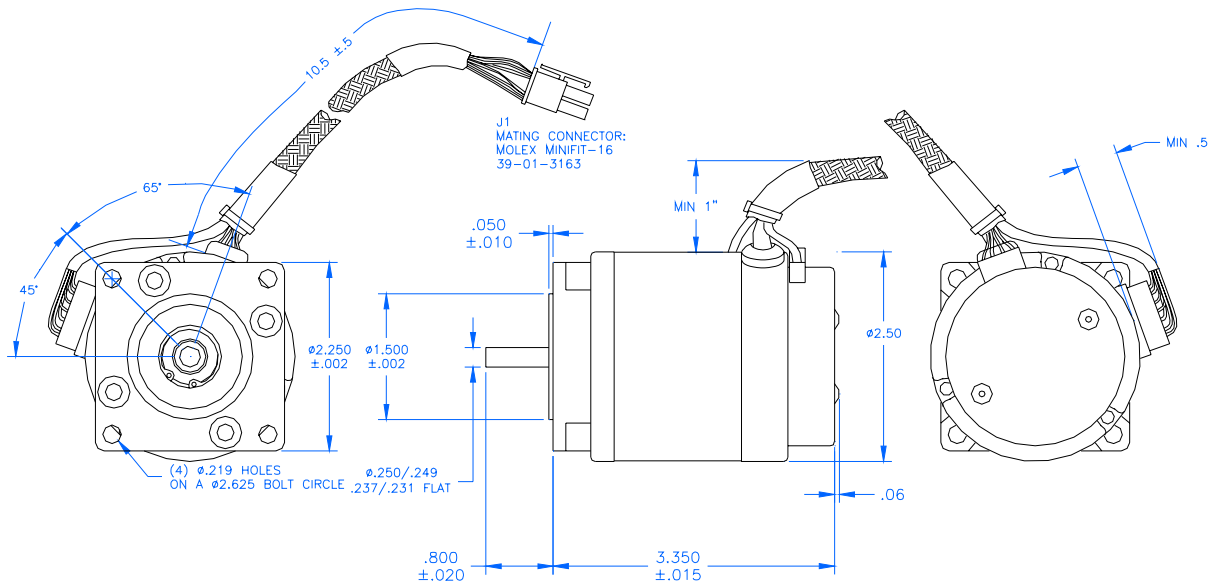

M-2330-FX: 4,000 counts/rev. with NEMA flange

To attach a Teknic NEMA adapter flange (p/n M23F) to your motor, use the #10-32 screws provided and secure the with thread locking compound (such as the Loctite #242 thread lock compound). Be careful not to inject the thread locking compound into the motor (the holes go all the way through the flange).

Note: If you are mounting directly to the motor without the NEMA flange, make sure your mounting screws do not extend more than 0.275 inches (7mm) into the motor face plate or serious motor damage may result.

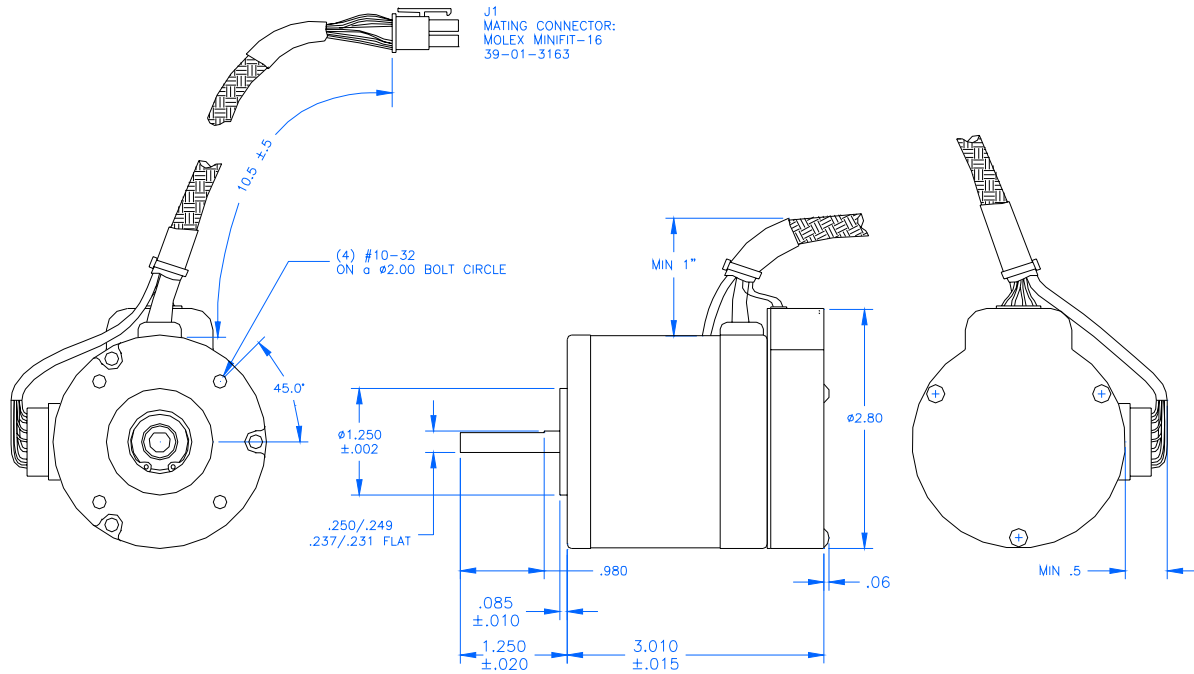

M-2330-XH: 8,000 counts/rev. without NEMA flange

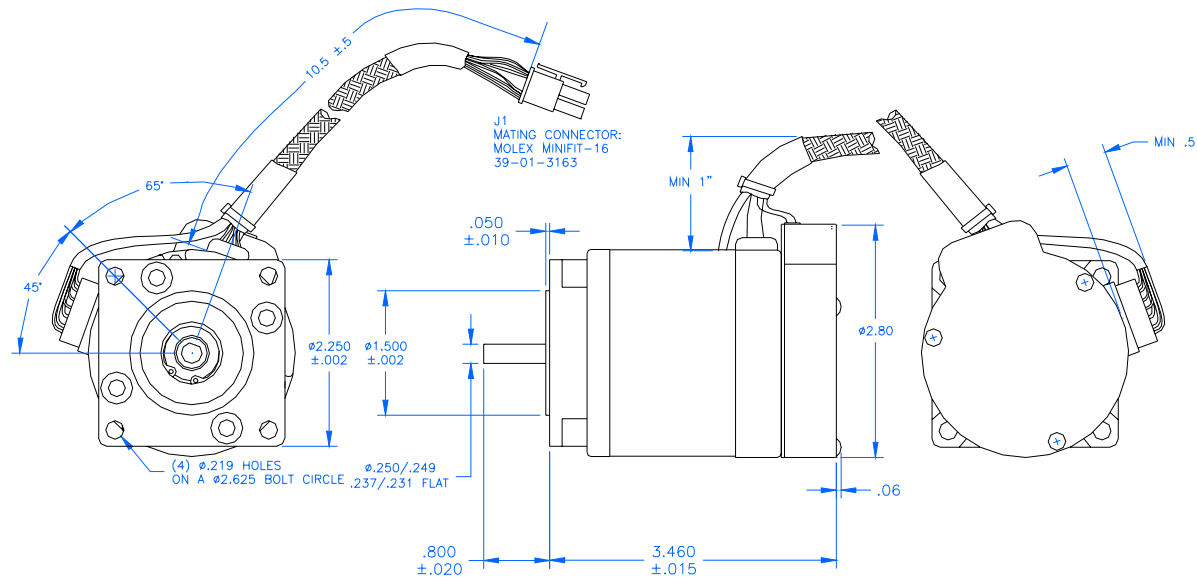

M-2330-FH: 8,000 counts/rev. with NEMA flange

To attach a Teknic NEMA adapter flange (p/n M23F) to your motor, use the #10-32 screws provided and secure the with thread locking compound (such as the Loctite #242 thread lock compound). Be careful not to inject the thread locking compound into the motor (the holes go all the way through the flange).

Note: If you are mounting directly to the motor without the NEMA flange, make sure your mounting screws do not extend more than 0.275 inches (7mm) into the motor face plate or serious motor damage may result.

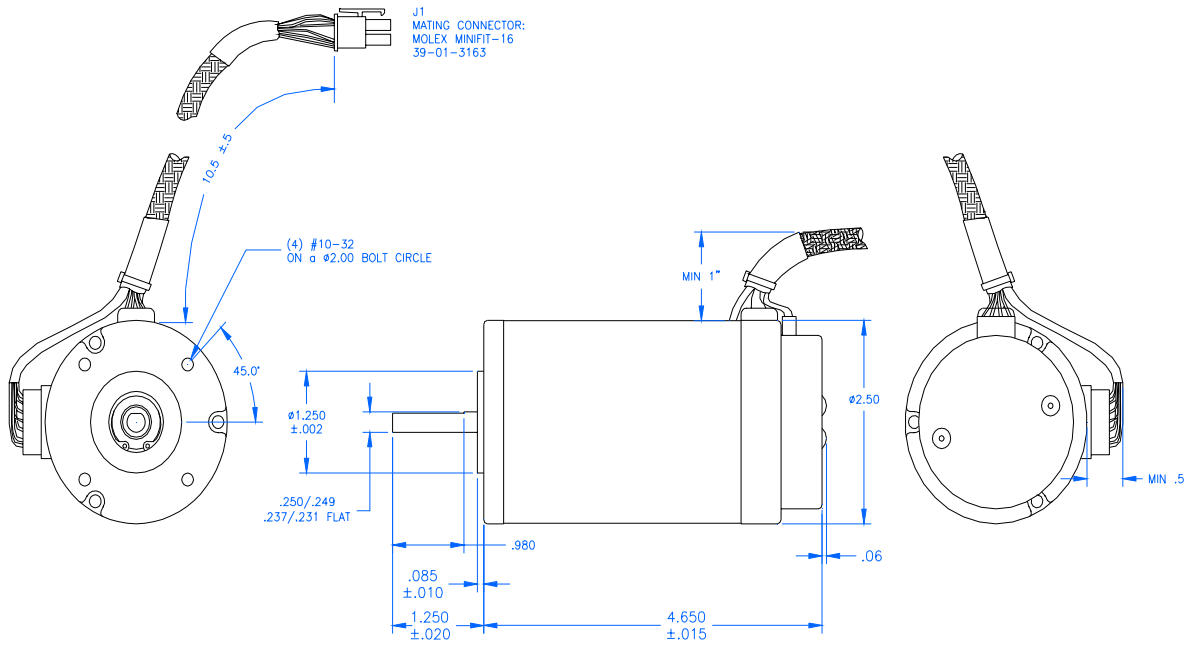

M-2348-XX: 4,000 counts/rev. without NEMA flange

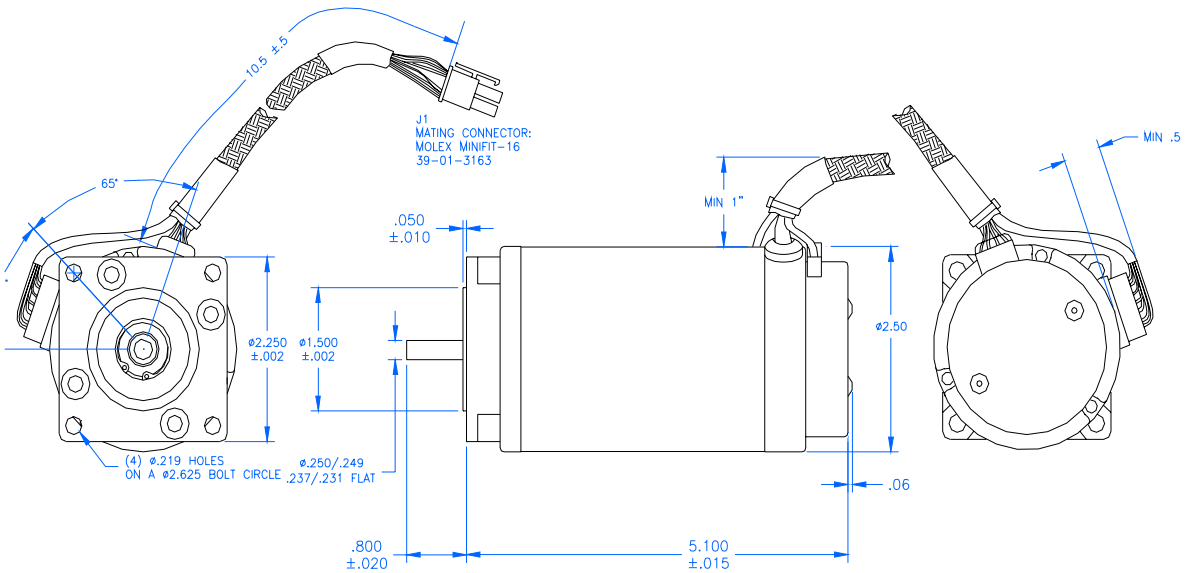

M-2348-FX: 4,000 counts/rev. with NEMA flange

To attach a Teknic NEMA adapter flange (p/n M23F) to your motor, use the #10-32 screws provided and secure the with thread locking compound (such as the Loctite #242 thread lock compound). Be careful not to inject the thread locking compound into the motor (the holes go all the way through the flange).

Note: If you are mounting directly to the motor without the NEMA flange, make sure your mounting screws do not extend more than 0.275 inches (7mm) into the motor face plate or serious motor damage may result.

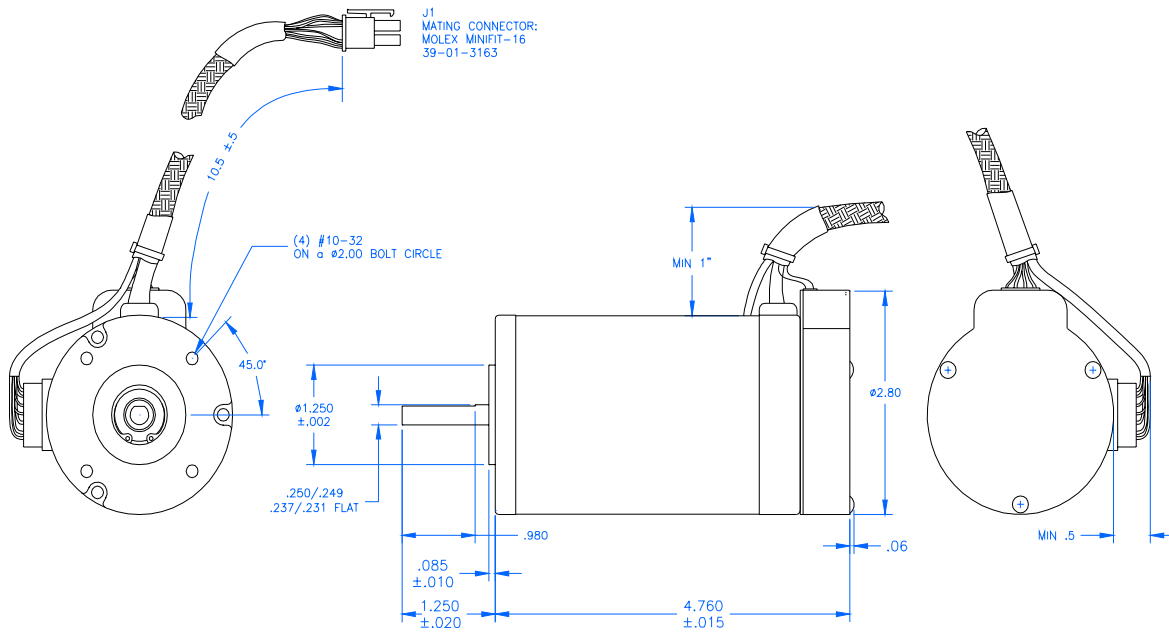

M-2348-XH: 8,000 counts/rev. without NEMA flange

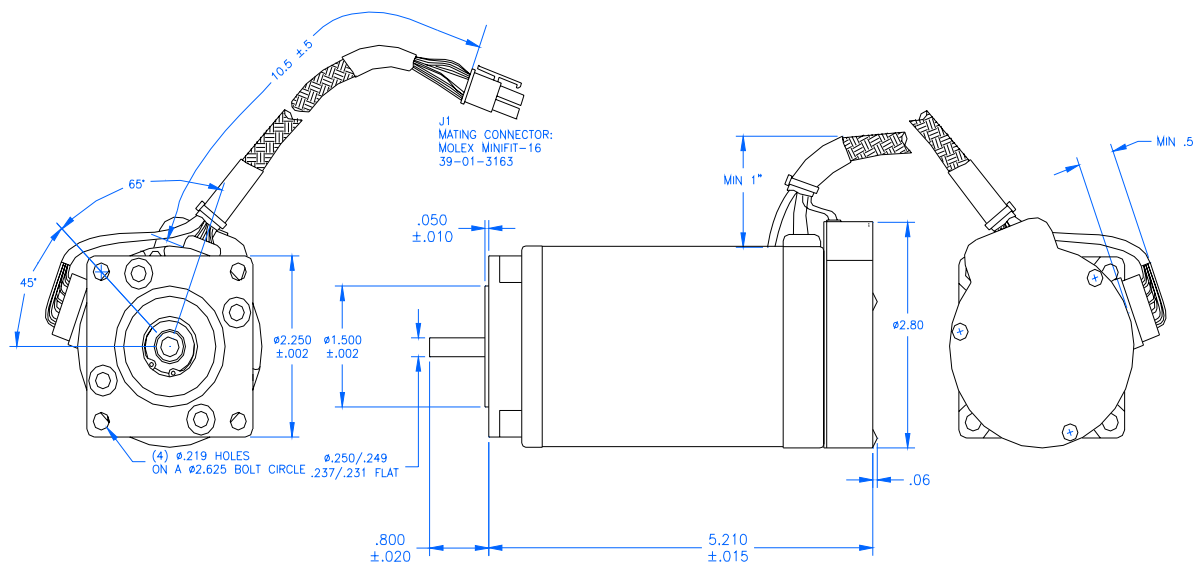

M-2348-FH: 8,000 counts/rev. with NEMA flange

To attach a Teknic NEMA adapter flange (p/n M23F) to your motor, use the #10-32 screws provided and secure the with thread locking compound (such as the Loctite #242 thread lock compound). Be careful not to inject the thread locking compound into the motor (the holes go all the way through the flange).

Note: If you are mounting directly to the motor without the NEMA flange, make sure your mounting screws do not extend more than 0.275 inches (7mm) into the motor face plate or serious motor damage may result.

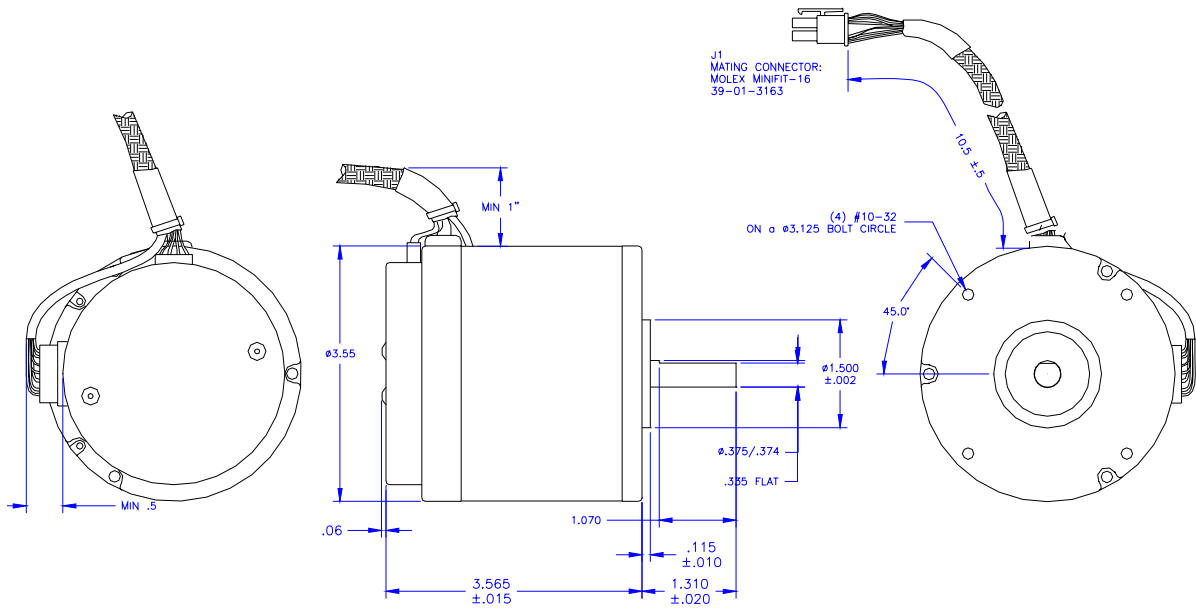

M-3437-XX motor without NEMA 34 flange

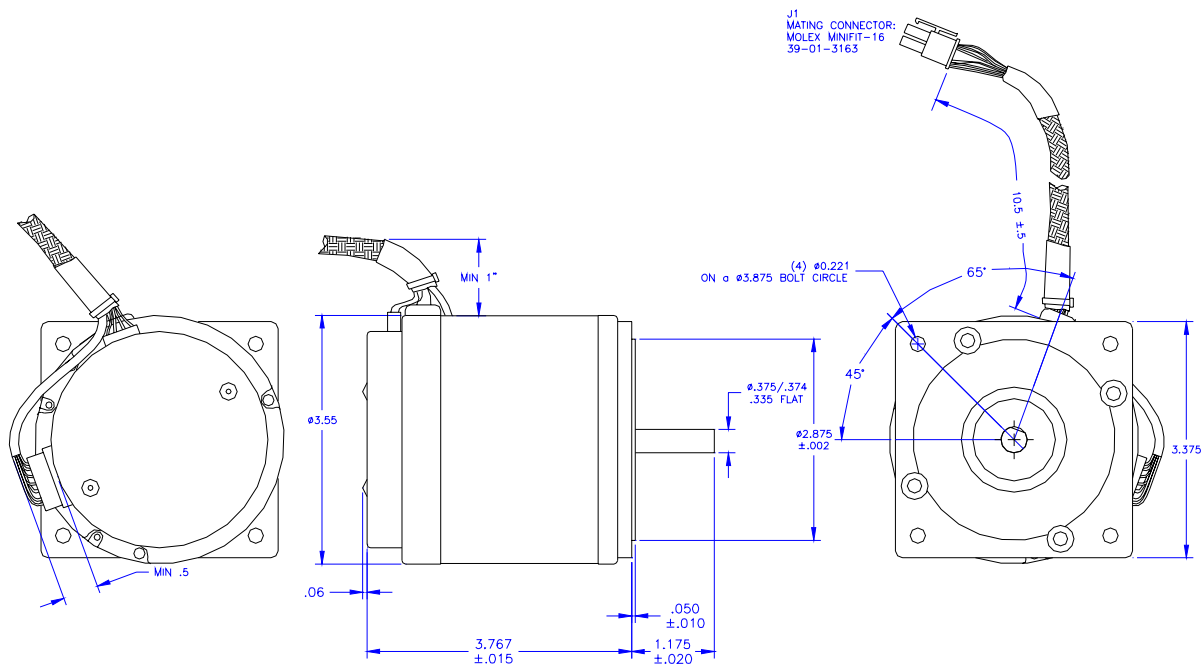

M-3437-FX motor with NEMA 34 flange

To attach a Teknic NEMA adapter flange (p/n M34F) to your motor, use the #10-32 screws provided and secure the with thread locking compound (such as the Loctite #242 thread lock compound). Be careful not to inject the thread locking compound into the motor (the holes go all the way through the flange).

Note: If you are mounting directly to the motor without the NEMA flange, make sure your mounting screws do not extend more than 0.275 inches (7mm) into the motor face plate or serious motor damage may result.

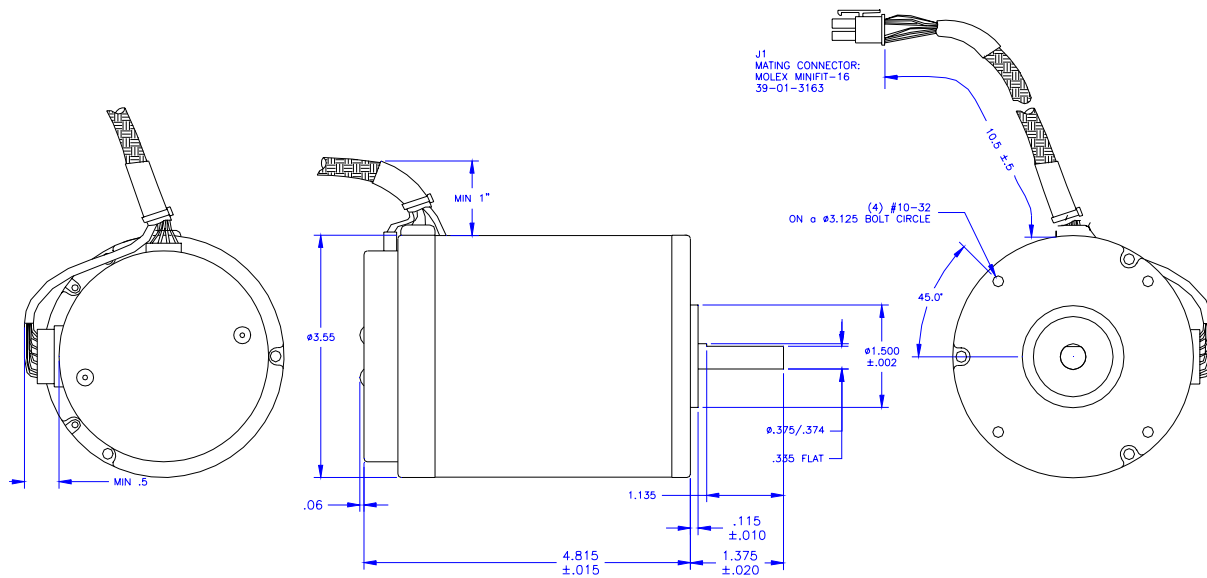

M-3450-XX motor without NEMA 34 flange

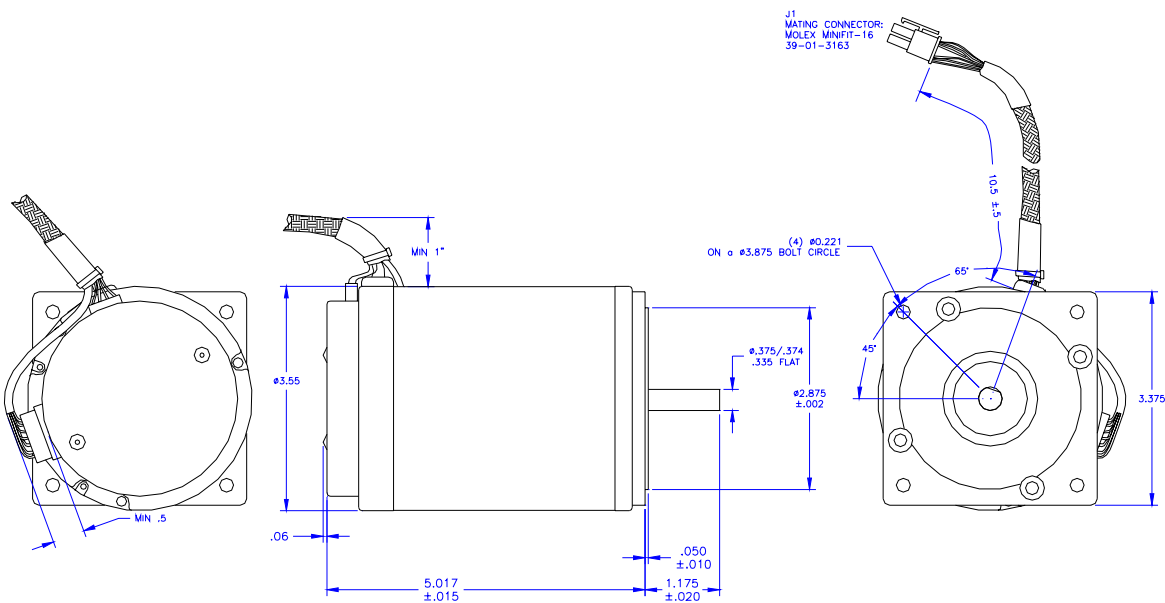

M-3450-FX motor with NEMA 34 flange

To attach a Teknic NEMA adapter flange (p/n M34F) to your motor, use the #10-32 screws provided and secure the with thread locking compound (such as the Loctite #242 thread lock compound). Be careful not to inject the thread locking compound into the motor (the holes go all the way through the flange).

Note: If you are mounting directly to the motor without the NEMA flange, make sure your mounting screws do not extend more than 0.275 inches (7mm) into the motor face plate or serious motor damage may result.

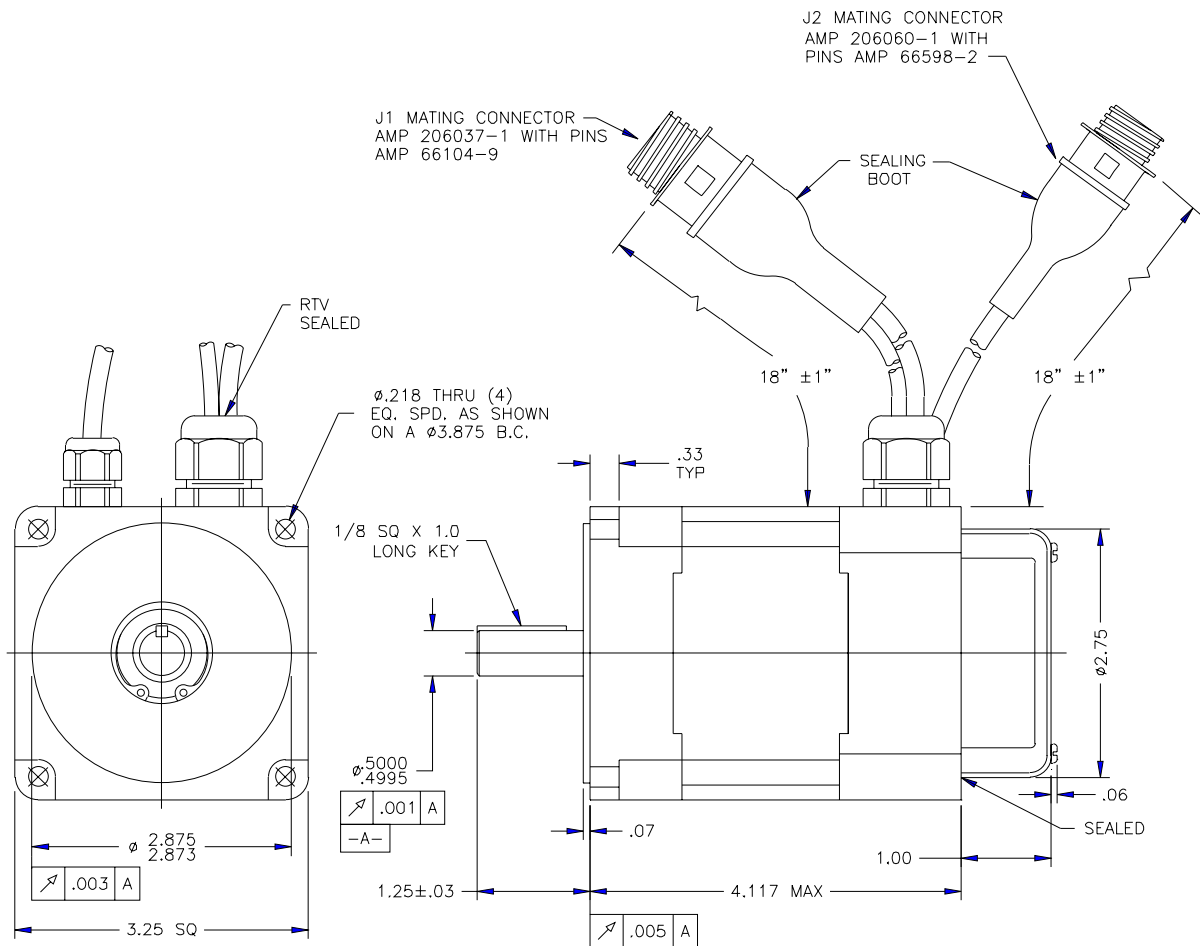

M-3462-FH sealed motor flange

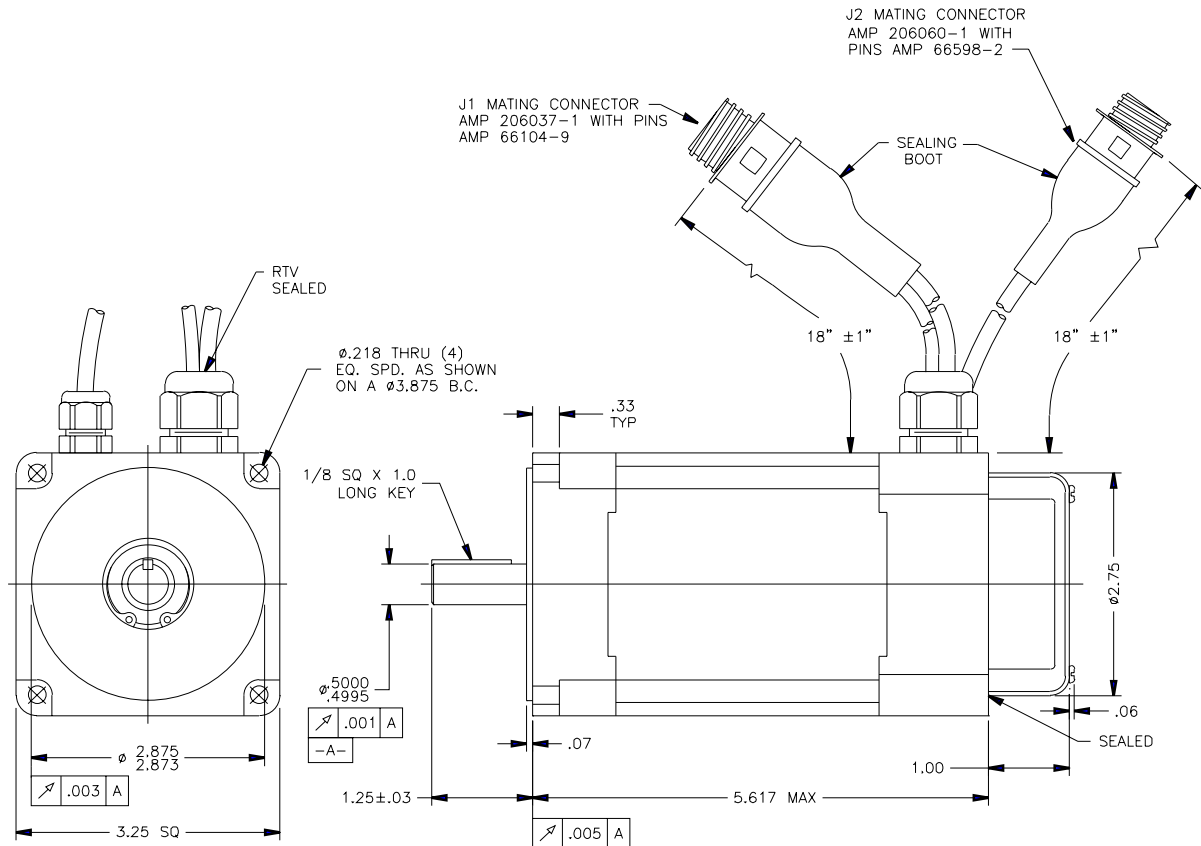

M-3471-FH sealed motor

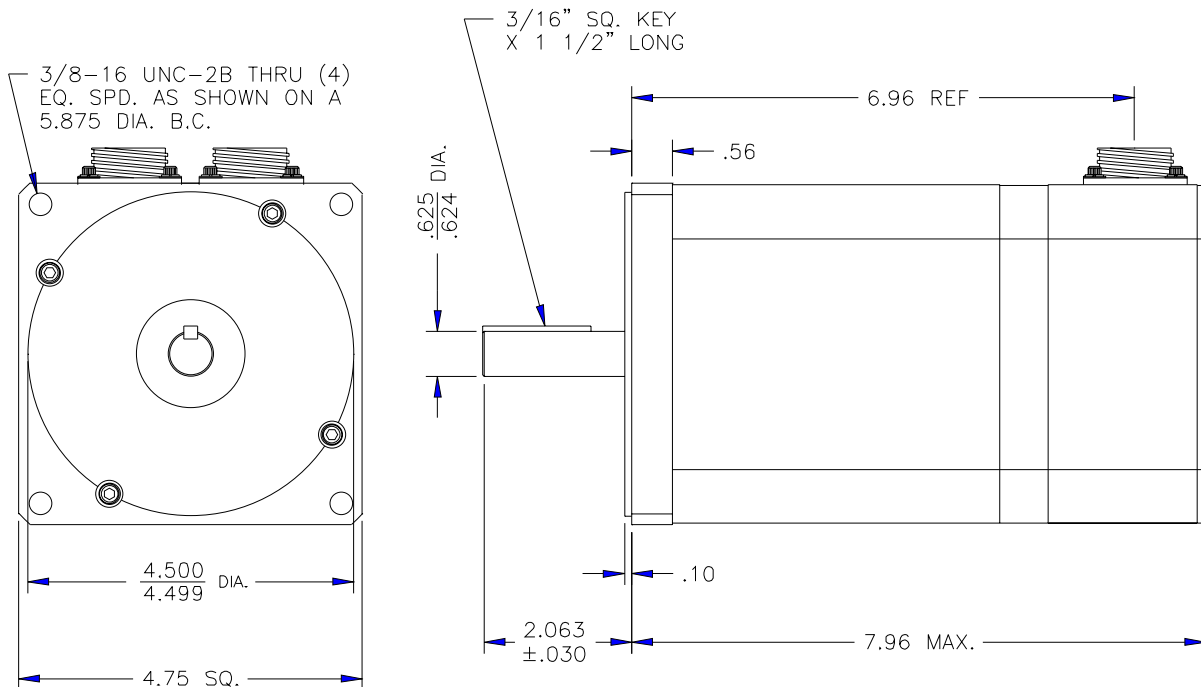

M-497P-FI and M-497T-FI sealed motors motors

AXIAL AND RADIAL SHAFT LOADING VS. BEARING LIFE

Teknic's line of rare-earth brushless motors have inherently high reliability under normal operating conditions. Since they are brushless motors, the only parts with mechanical contact are the shaft bearings. The bearings used are oversized, single row, deep groove radial bearings with non-contact lubrication seals. The large ball bearings have diameter variations of less than 15 millionths of an inch, and the steel used is vacuum degassed and heat treated for maximum endurance.

The expected life of Teknic motors is, therefore, dependent mainly upon bearing life.³ Under normal environmental conditions⁴, bearing life is dependent upon the applied axial (thrust) and radial (side) loading. The relationship between bearing life and loading is shown in the graphs below. The definition for "life" is "rated life, L₅" which is the life that 95 percent of the bearings will surpass. The units are in millions of revolutions. To calculate the years of expected bearing life use the following formula:

$$Life(in\ years) = \frac{10^6 \times Life(in\ millions\ of\ revolutions)}{avg\ RPM \times duty\ cycle \times 60 \times \left(\frac{hours}{day} \times \frac{days}{week} \times \frac{weeks}{year} \right)}$$

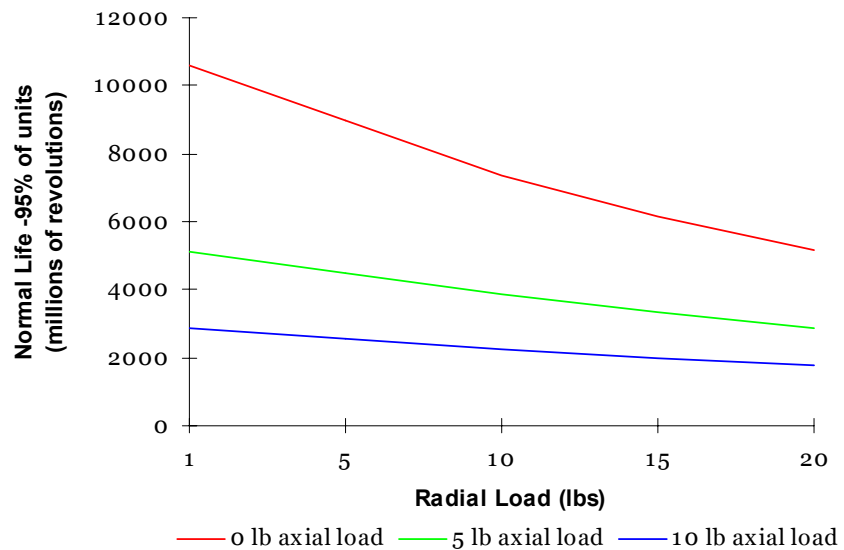

Bearing Life vs. Load—23 series motors

- 3 Winding insulation breakdown can become an important factor if the motor is run at a winding temperature of over 155°C for any period of time. As long as the winding temperature is kept under this value, insulation breakdown will not normally be a problem. This winding temperature corresponds to a steady-state case temperature of about 75°C under most thermal transfer conditions.
- 4 Non-corrosive atmosphere at 0-90% relative humidity (non-condensing) with moderate levels of airborne contaminants.

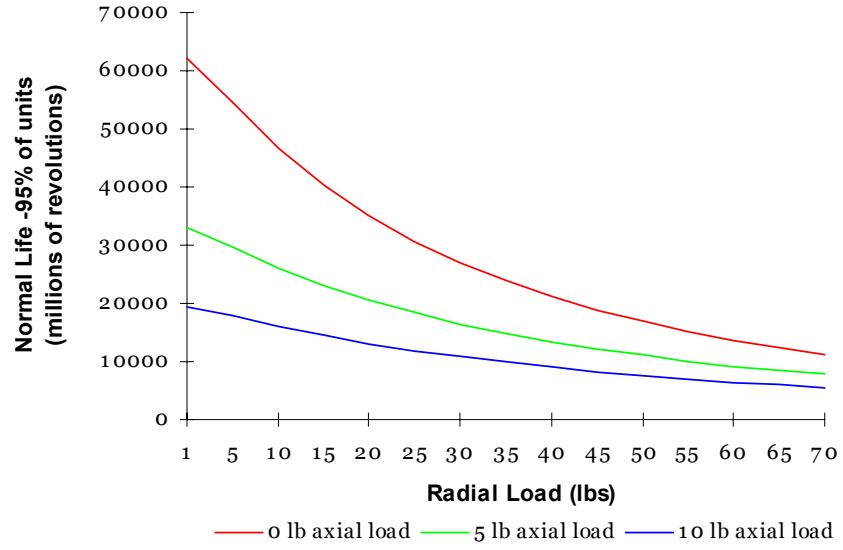

Bearing Life vs. Load—34 series motors

ENCODER FEEDBACK IN YOUR APPLICATION

Because a dedicated DSP within the SSt servo drive is constantly monitoring the position, velocity and torque of your axis and making corrections on a microsecond timeframe you get the highest level of servo performance available today. In addition, the SSt servo drives have several built-in functions that execute in real time on the internal DSP that “assist” your control code while providing high-level signals to verify proper operation and help you synchronize events. These built-in DSP functions do faster and more robustly what you may have been forced to do in the past within your control code using secondary encoder feedback at the controller. We’ll show you how, using these built-in functions, you can meet your application requirements while avoiding the costly integration of secondary encoder feedback at the controller. This will make your code far simpler and easier to debug, while increasing your machine reliability.

You probably have several questions concerning how you could accomplish certain functions without secondary encoder feedback at your controller. We’ll discuss how (with one notable exception) you can accomplish these functions when using the SSt servo drives without secondary encoder feedback at your controller. In fact, because the SSt servo drives are so robust, the overall reliability (and usually throughput) of your machine will probably be improved if you *don’t* use secondary encoder feedback at your controller.

There are several requirements that using secondary encoder feedback at your controller could resolve:

- Verification of move completion;
- Watching for positioning errors;
- Homing of axes;
- Clamping objects or inserting objects into sockets/fixtures;
- To facilitate manual calibrations
- For effective error recovery, and/or
- “Absolutely precise” on-the-fly synchronization with other events.

All of these above needs can be accomplished without secondary encoder feedback when using the SSt servo drives except the last one⁵. We’ll explain how each of these is needs is facilitated by the SSt servo drives and some simple control sequences.

So lets examine each of these requirements in turn:

VERIFICATION OF MOVE COMPLETION

In some point-to-point applications the machine cycling is interlocked with a verification that the move is complete to some desired accuracy. Typically the control software keeps reading the encoder position on a periodic basis as part of its “scan” to verify this. To reduce errors, this is typically done several times and perhaps compared with a timer to check that the axis has been done for some period of time. Because the CPU is usually working on numerous tasks this qualification process typically

⁵ If your application does require on-the-fly synchronization to the *exact* encoder count you will need an encoder feedback card for use with this soft controller or a commercially available indexer card with encoder feedback but *only for the one or two axes in your machine that require this.*

adds between 20mS to 50mS of latency for every move in your machine (decreasing your throughput).

The SSt servo drive can greatly offload your control code by doing this processing for you. The MoveDone signal is a high level TTL signal that actuates when the position error at the end of the move has been within a desired accuracy for a qualification period of time. Both the accuracy and the qualification period are configurable and are usually set to a few counts and a few milliseconds. The MoveDone signal is calculated every 100uS to eliminate latency and it also has fuzzy logic false triggering suppression (which suppresses the signal if it “looks like” the position will move out of the accuracy window).

WATCHING FOR POSITIONING ERRORS

In some instances you want to shut down operation or take preemptive action if the position error on one or more axis goes above a certain level. Instead of your control code having to constantly monitor the secondary encoder counter and calculate whether it is “in-band” during moves, the SSt servo drive can do this for you in two ways:

If you want to shutdown (perhaps for safety reasons) the axis when this occurs, the SSt servo drive can do this automatically for you based upon a pre-configured error limit set in the drive. If this happens, the Ready line will notify your control code, by de-asserting.

If you want, instead (or in addition), to take preemptive action when the error goes beyond a certain level you can configure the MoveDone line in “In-Range” mode. This line will assert whenever you are outside of your pre-configured accuracy range. Your control code can then slow down immediately (a typical response in a CNC or soft cam application), finish the current cycle and then stop (so the operator can check for problems) or just log and flag the condition for preventative maintenance to occur.

HOMING THE AXES

The SSt servo drives have two built in functions to assist in precisely homing an axis: Limit Switch Homing and Hard Stop Homing. Both of these methods eliminate the normal control sequence that occurs when homing an axis with an indexed encoder:

Move to a switch rapidly, then “crawl” to the index pulse of the encoder, perhaps refining the home by moving one encoder tick at a time in a loop until the index is seen, look up the software offset stored in memory (because the index mark cannot be mechanically adjusted) and move that distance to the home position.

Instead, with the SSt servo drive’s Limit Switch Homing the axis is jogged until the limit switch is detected by the controller code. The SSt servo drive will lock the axis at the precise limit switch position. Using this mode and an inexpensive small aperture optical switch you home the axis repeatably to within a fraction of a micron. Your control software then simply sends the axis away from the limit switch to a standard home position.

Your code can even ignore the limit switch signal if you want the routine to be even simpler. This is how this works—

Let's say that you have an axis that is 100,000 counts long. You simply make a moderate speed move toward a limit switch of 100,100 counts. At some point during the move the axis will contact the limit switch, at that point the SSt will automatically ignore further pulses in that direction. Any pulses in the other direction (away from the limit switch) will be responded to as usual. So after the completion of the 100,100 count move you simply command the axis to move away from the limit switch by a fixed amount to a precision home position.

Hard Stop Homing will provide the same function for you without any switch! Hard Stop homing allows you to home an axis with excellent precision by simply driving the axis into a hard mechanical stop at a moderate speed. At some point during the move the axis will contact the mechanical stop, the SSt servo drive will automatically sense the hard stop, fold back the torque/force to a low level, ignore further pulses in that direction and assert the MoveDone signal. You can choose to monitor MoveDone to speed up homing or simply "overdrive" the axis into the stop (as in the 100,100 count example above). Any subsequent pulses in the other direction (away from the mechanical stop) will be responded to as usual. So after the completion of the Hard Stop Homing move you simply command the axis to move away from the mechanical stop by a fixed amount to a precision home position (usually repeatable to within one encoder count if the axis is relatively stiff).

CLAMPING OBJECTS OR INSERTING OBJECTS INTO FIXTURES

Some applications need to insert a part into a test socket or clamp an object at the end of a stroke. Typically, this is done with a servo control board by: watching the encoder counter, looking for a sharp increase in error and using one or more relatively complicated techniques to control the torque/force at the end of the move. For example, one technique is to turn off the position compensator's integrator and move beyond the point where error is detected by a certain amount. Another technique usually involves switching from position into torque/force control mode on-the-fly (which usually is complicated to manage, especially when switching back to position mode).

The SSt servo drives can relieve your control code by seamlessly doing this torque/force control for you. There are two ways in which this can work:

If you are simply interested in clamping a robust object at the end of the move you can use MoveDone torque fold-back. When the end of a move is detected the torque will fold-back to a pre-configured value after a few milliseconds. This will hold the object with a known force and keep the motor and drive from overheating or going into safety shutdown. No extra control software is required to support this, just configure the SSt drive and you're done. This method, however, will apply near full torque/force for a few milliseconds before it folds back (so you would not use it to clamp an egg).

If you want to be gentler during clamping/insertion you can use the Mode input signal to limit the torque/force for you. It can be set up to limit the torque/force to a pre-configured value in the positive direction only, the negative direction only, or both directions. You can use this with an optical or magnetic switch that will assert the Mode line as you get near the clamping position. This will limit the torque/force as the part is clamped/inserted but will allow full torque in the opposite

direction for fast retracts. No extra control software is required to support this, just configure the SSt servo drive, set up the switch and you're done. Optionally, you can control this line from the soft controller to avoid the switch.

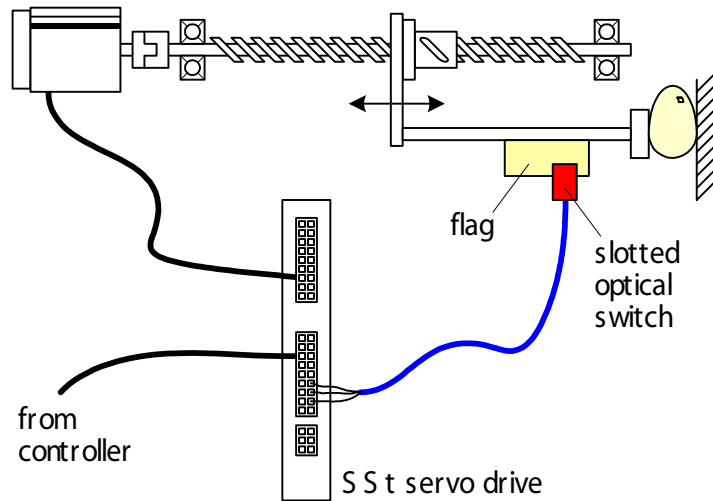

Using Mode line torque foldback for clamping delicate objects

TO FACILITATE MANUAL CALIBRATIONS (ALIGNMENTS)

In some older stepper motor application, manual calibration is accomplished by a technician moving the axis by hand to a calibration point and then, upon leaving the calibration mode the control software reads the encoder to calibrate the machine. There are numerous safety reasons to not do this on a servo driven machine. However, it can be useful to support this mode. An easy way to do this without encoder feedback is to disable the drives to allow the movement and then, after re-enabling, home slowly to a limit switch to detect the calibrated position. (If you know the approximate distance between the calibration position and a limit switch you can speed this process by making the largest move possible that is sure to be short of the limit switch and then move slowly to the limit.)

Other alternatives include:

Allowing the technician to jog the axis to the calibration position after you have homed the axis (the calibration is then calculated by summing her movements during the calibration procedure).

Using Hard Stop Homing to do a definitive mechanical calibration (see "Homing the Axes" above). You can do this by:

1. driving the axis to an end stop of the axis and depend on the tolerance of the mechanics for alignment,
2. driving the axis to a stop near a critical point in a machine that is inserted via pneumatics, a solenoid, by a hand toggle, etc. or,
3. by stopping against a fixture that will normally be inserted "in the way" of the axis during machine operations e.g. a tray, etc.

So you don't need secondary encoder feedback when calibrating your machine if you use the SSt servo drives. In fact, using Hard Stop Homing

you might be able to remove the manual alignment altogether making the procedure more repeatable.

FOR EFFECTIVE ERROR RECOVERY

The argument for using secondary encoder feedback for error recovery has many variations but goes something like this—

“If I know where I am after a machine fault or e-stop is detected, I can rapidly resume operations without having to re-home all the axes”

Let’s examine why this is likely not to be a valid argument:

1. How “fail-safe” is the secondary encoder count? In fault situations it is likely to be dubious. Noise, loss of power, mechanical disconnect can, and often do, corrupt this information. Especially considering you just have had a “fault”, making the assumption that the secondary encoder count is rock solid is not usually considered prudent engineering practice.
2. Does it matter if it takes a few extra seconds to re-initialize after one of these events? Ask marketing. If it does, couldn’t you employ some more rapid homing routines to reduce the time? (You are using a rapid servo axis, after all.) How quick does this recovery need to be? (Sometimes just changing which end of the axis is used as home can save significant time.)
3. What sort of effort is required to make a control program that would:
 - a. Calculate (using the secondary encoder count) the precise machine state at the time of interruption. (Especially considering that one or more of the axes have probably coasted since the interruption occurred.)
 - b. Figure out how to drive the machine state, in the most optimum way, avoiding potential obstacles, to the desired state to continue operating without damaging product?

Upon some careful discussion/analysis of all the possible permutations that can occur during an interruption, this often turns out to be a massive undertaking that it not worth the effort and/or has fault opportunities of it’s own.

In most machines it’s overwhelmingly likely that their exists a simple re-homing sequence that will resume operations without damaging product (if it has not been damaged already) after a fault, e-stop, etc. Sometimes they’re are a few of these sequences depending on which axis, or group of axes, faulted, but very rarely, if ever, do they need to (or should they) rely on the secondary encoder data for proper operation. The most robust error recovery strategy is to find these simple re-homing sequences and use them without relying on potentially corrupt secondary encoder data. You may lose a few seconds on average in the event of a fault by not using secondary encoder data in these sequences, but you will gain enhanced system reliability and typically, faster time to market with your machine.

CONSIDER SECONDARY ENCODER FEEDBACK CAREFULLY

You might be reading this saying: “Yes, but I still feel more secure if I *know* where the axis is because...”

In fact, having an extra sensor monitor an operation makes excellent sense when the sensor has significantly higher reliability than what you are monitoring. If, in the past, you were monitoring an unreliable stepper motor (that could stall, or not microstep properly), it made perfect sense to do all that encoder processing and you probably feel comfortable with the secondary encoder feedback. However, with SSt servo drives, in most applications, reading the encoder with a secondary input at the controller usually creates far more opportunities for failure than it cures.

Let's look carefully at what you would probably be *giving up* by reading the encoder:

The SSt servo drive probably has the most robust encoder interface on the planet. It includes RF suppression, analog filtering, digital filtering, bad sequence detection and consistency checking performed by the DSP. The effect of all these precautions is to eliminate, or in the worst case definitely detect, noise-induced errors. (This is why the SSt can easily work with single ended TTL encoders while competitors always recommend, or insist on, encoders with differential signals.)

If the secondary encoder processing electronics in a controller is not as good as the SSt servo drives (which is likely) you can, in the typically noisy environment of a machine, inaccurately "second guess" the SSt servo drive by reading the encoder. Keep in mind that the SSt servo drives reads the encoder every 100uS not only for control but also to run MoveDone signal, flag tracking errors and to check for bad sequences so you don't have to. Even if the controller's secondary encoder count doesn't get disturbed by noise, your control code could easily read the encoder out of sync with the internally modified RAS profile and think the axis it was in the wrong position. And then, actually tell the SSt servo drive to move to away from the desired position because the controller misread or misinterpreted the encoder.

In addition, piping high-speed encoder signals throughout the machine leads to more expensive assembly costs, higher material costs, higher risk of EMI interference, and lower reliability due to more connections.

Although it's beyond the scope of this discussion, if you are considering a central servo controller board (which of course gives you access to the encoder counter), you will not get servo performance equivalent to an SSt servo drive in terms of efficiency, smoothness, settling time, etc. (Go to www.Teknic.com and look at the "Servo Architectures—Pros and Cons" for a discussion on why this is true).

All and all, systems that don't read the encoder signals when using an SSt servo drive, are more reliable, take less time to develop and have lower costs.

The bottom line is: If you don't need absolutely precise on-the-fly position registration you can improve the reliability, lower assembly costs and reduce software hassles by using the SSt servo drive's features *instead of* using secondary encoder feedback at the controller.

SST-QUICKSET™ CONFIGURATION AND INTEGRATION SOFTWARE

SSt-QuickSet™ is a configuration and integration software package that allows you to: (1) easily and quickly set up an SSt servo drive system, (2) optimize it for your mechanics, (3) verify, quantitatively, its performance, and then (4) save your optimum configurations for speedy, mass-configuration of SSt servo drives™ during machine production.

Because SSt-QuickSet™ does all the configuration of an SSt servo drive electronically, you don't need to ever set potentiometers, DIP switches or jumpers. All of the configurations can be stored on your computer for quick transfer into other SSt servo drives™-minimizing set-up and troubleshooting time during production. Each SSt servo drive has a unique electronic serial number so SSt servo drives™ and their configurations can be tracked easily.

SSt-QuickSet™ also allows you to monitor the performance of the drive during machine integration. You can view position and velocity in user defined units and monitor the full status of any SSt servo drive right from your computer screen. SSt-QuickSet™ also allows you to set up its internal stimulus generator and Real-time Monitor port. These built-in instruments within SSt servo drive can be used in conjunction with your oscilloscope to stimulate and monitor the performance of your entire electro-mechanical system, giving you a capability you never had before.

Note: Aside from the SSt-QuickSet™ installation instructions below, all the software documentation you need is provided on-line for easier access.

Every section of every window contains a Help button, allowing you to easily and quickly access any information you need. Help is also several levels deep so it's useful for beginners as well as experienced users. Beginners can look up unfamiliar terms within the text at the touch of a button (without losing their place), and experienced users can dig as deeply as they want for detailed technical information.

REQUIRED HARDWARE

SSt-QuickSet™ runs on IBM PC compatible computers with a 486/Pentium CPU, a minimum of 16MB of RAM, a CD-ROM, 10MB of free disk space and a free serial port. (The serial port cannot be shared with other active serial devices such as a mouse).

Required software is Microsoft Windows™ 95, 98 or NT4.0 SP3 or better.

SST-QUICKSET™ INSTALLATION

Insert the SSt-QuickSet™ installation CD-ROM into your drive on a Windows 95, 98 or NT4.0 computer. If *AutoRun* is enabled, the installer will start shortly after inserting the disk. If it does not start, open a window to the CD-ROM drive and run the application program SETUP.EXE.

An installation screen will appear and ask you to select a destination on your hard drive, etc. The installation process will take a couple of

minutes. An SST-QuickSet™ icon and group window should appear on your screen as well as the in the Start menu under the Teknic folder.

Your installation is now complete.

Before you attempt to communicate with SSt servo drive, make sure that you have connected COM 1, 2, 3 or 4 to SSt servo drive via the Diagnostic/Configuration cable shown in the Diagnostic Port Section above. Also make sure that you have applied power to SSt servo drive.

If you wish to remove this application, use the Add/Remove Programs icon in the Control Panels folder. Select “Teknic SST-QuickSet” item from the list of applications.

USING SST-QUICKSET™

Most often SSt drive configuration is accomplished using two windows within SST-QuickSet: The main window and the Inputs & Limits window. These are shown below with call-outs explaining major functions.

The screenshot shows the SST-QuickSet V4.0.17 configuration window for file M2348. The interface includes a menu bar (File, Edit, COM Port, Setup, Help), a status bar (Online, Enabled, Input: 4,000 steps/rev., 75 VDC, Load RMS: max 0%, 0%), and several functional panels:

- Tuning Stimulus:** Includes Type (Torque, Velocity, Position), Amplitude (200 quad counts), and Period (250 ms).
- Tune Setups:** Buttons for 1-Kv, 2-Kp, 3-Ki, 4-Undo, and Help.
- Monitor Port:** Shows 100,018 steps/sec/div. @ 0.5V/div. range, with Variable (Commanded Velocity (RAS)), Filtering (f), and Sync Pulse (Both) options.
- Current Position / Velocity:** Displays -9 quad counts and 0 steps/sec.
- Shutdown Messages:** A list box for error messages.
- Real-time LEDs:** A section for drive status indicators.
- Compensator Tuning:** Main Gains (Velocity (Kv): 11,000, Position (Kp): 9,000, Integral (Ki): 400) and Feed-Forward Gains (Velocity (Kfv): OFF, Acceleration (Kfa): 2,000, Torque Bias (% of max.): OFF).
- Anti-Hunt:** On/Off toggle.
- Regressive Auto-Spline:** 4 ms Fit Length.
- Inertia Matching Technology:** 1,000 Krv, OFF Knp, and Torque Rise Time (us).
- Buttons:** Store, Swap, Auto Tune..., and Help.

Callouts provide detailed explanations for these features:

- Drive State Indicator:** [Double click to clear shutdowns.]
- Input Mode Display:** [double click here to open Inputs and Limits Screen]
- Tuning Setup buttons:** make for easy tuning
- RMS Meter:** displays load in real time [Peak hold function allows you to easily test for worst case loading.]
- PIV compensator:** is easy to tune. [much easier than PID]
- Feedforward Gains:**
- Torque Bias offset:** removes asymmetrical tuning problems with gravatational loads.
- Exclusive, RAS:** Automatically jerk limits your incoming digital command.
- Exclusive, IMT:** Adaptive compensation to quell overshoot even with large inertial and varying loads.
- Store and Swap buttons:** allow for rapid A-B testing of different tuning set-ups.
- The Real-time Monitor Port's sync pulse:** makes for easy, repeatable scope triggering and overlays.
- Built-in square wave generator:** for checking tuning under worst case conditions.
- Real-time Monitor Port controls:** allows you to view torque, velocity, tracking accuracy & more as your machine runs.
- Position/Velocity readout:** can be set-up to display in user units: M/sec, inches, etc.
- Shutdown messages:** help you quickly troubleshoot problems in your machine.
- Real-time LEDs:** show you the status of the SSt servo drive. [Even sub-millisecond events are "stretched" for display.]

QuickSet Main Window

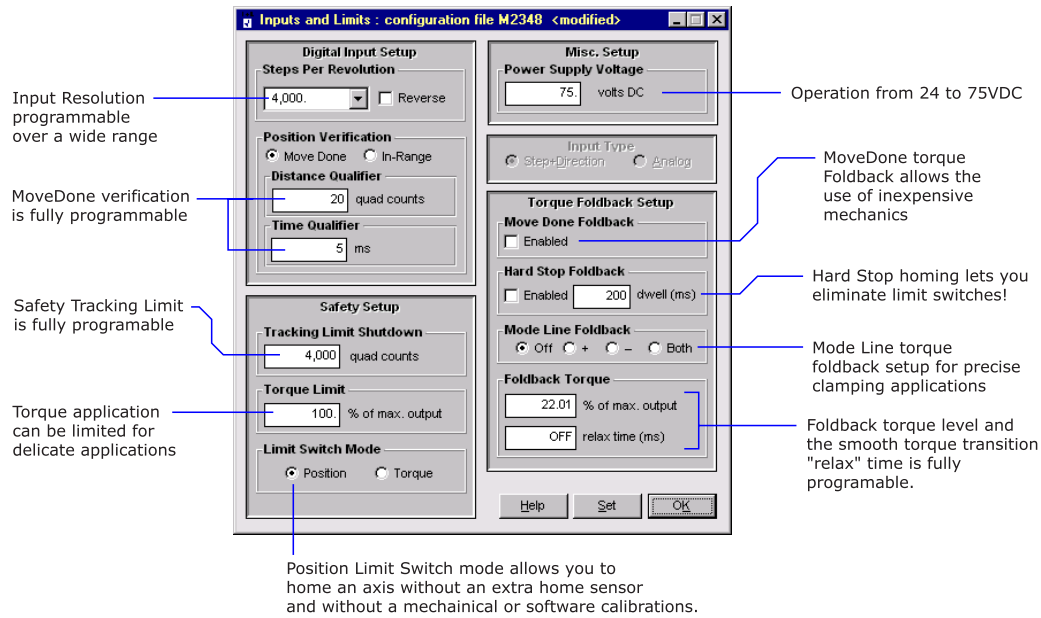

QuickSet Inputs&Limits Window

USING HELP (SST-QUICKSET™ DOCUMENTATION)

Each setup and utility window in SSt-QuickSet™ has context sensitive help for each of its items. To invoke the help screen for any item, hit the F1 function key when that item is selected. To find out more on using Help itself, pull down the Help menu and select the Help On Help... item.

HAVING TROUBLE INSTALLING SST-QUICKSET™?

Due to the wide variations of Microsoft Windows™ environments and PC hardware, you may experience compatibility conflicts that may cause erratic SSt-QuickSet™ operation. Here are some things to look for.

PROBLEMS DURING SST-QUICKSET™ OPERATION

Problems during program operation are generally caused by serial port problems. The symptoms are:

- Drive won't respond (drive is always "Offline")
- Communication with drive is intermittent and erratic

Drive Won't Respond ("Offline")

The operation of serial ports on the ISA bus and under Windows™ is unfortunately one of the weak links of a PC-based system. On the hardware side, there is a lack of serial boards with flexible I/O addresses and interrupts, or plug-and-play setups. On the software side, some Windows™ configurations implement a poor set of low level drivers and support to the hardware. The combination of these two factors can cause problems in software that requires access to the serial port. SSt-QuickSet™ uses the serial port regularly in the course of its execution to talk to the SSt servo drive.

If you cannot talk to your drive with SSt-QuickSet™, as evidenced by the word "Offline" in SSt-QuickSet's™ main menu bar, the first step is to make sure you are not using the serial port by some other part of Windows.

The second step to solving serial port problems is to determine if your hardware is working. Windows™ and many ROM BIOS programs provide a utility to analyze your hardware. For Windows 95/98 look for "?" or "!" items in the Hardware tab of the System control panel. For Windows NT 4.0, run the Windows NT Diagnostics and Event Viewer applications located in the Administrative Tools to find clues as to what ports are available.

Intermittent or Erratic Communication

If you can basically run the drive and display information from the drive with SSt-QuickSet™, but the program periodically tells you the drive is going "Online" and "Offline", your serial port is having trouble.

Here are a few things you can try that may improve the operation of your serial port, and thus SSt-QuickSet™.

- Check any extension cables for open wires on the RS-232 control signals. If these lines float they may be interrupting your machine with unnecessary work. The SSt-DC cable is wired to make COM port see an on-line modem whenever the PC is powered up. If you have a break-out box, loop the PC's DTR to DSR, DCD, RI and CTS at the PC end of the cable. See the section on the Real-time Monitor port for more details.
- For older machines make sure serial port based on the 16450 chip (the 16550A chip is even better).
- Check for interrupt and I/O address conflicts on the serial port.
- Try removing any LAN drivers or the connection from the LAN to your machine.
- If you have too little memory, Windows™ may be swapping too much to your hard disk. Add more memory to solve this problem.
- Get a faster machine. A slow machine and display card may cause some of the time-outs.

OPTIMIZING SYSTEM PERFORMANCE (TUNING)

Although SSt servo drive is a state-of-art servo system, you don't need any knowledge of control theory, Laplace or Z transforms, etc. to optimize your system. All you need is an oscilloscope, a copy of SSt-QuickSet™ running on your Windows™ PC and the mechanical system that is to be controlled.

With SSt servo drive, you can optimize system performance simply by adjusting "soft" gain parameters. No mechanical tuning is required as with a stepper motor (no dampers, precise inertia matching, etc.) Nor do you need to set any pots, DIP switches or jumpers as with most other servos. In addition, you can see exactly what's happening, millisecond by millisecond, using the Real-time Monitor port, so there is no guesswork involved.

SERVO GLOSSARY

SSt servo drive works by continuously adjusting the amount of torque being applied to the motor shaft in response to a commanded signal (torque, velocity or position), and feedback from an encoder mounted on the back of the motor. The sophisticated software algorithms that calculate and adjust the instantaneous torque output need some information about the mechanical system and the performance objectives of the system in order to work effectively. This information is entered by the system designer in the form of various numerical gains. When we talk about optimizing system performance, we are referring to the process of adjusting these gains appropriately.

With SSt servo drive, the optimization process is easier than ever. It no longer has to be done by feel by an expert. Built-in stimulus/response instrumentation makes the process systematic and straightforward. If you are an experienced servo veteran, you'll be excited at how much more effectively you can use your knowledge and expertise with the SSt servo drive's measurement capabilities. For servo neophytes, it will be easier to understand the optimization procedures that follow, if we begin by defining some terminology:

Compensator: The algorithm that calculates the amount of torque to apply to the motor, based upon the feedback from the encoder sensor.

Feedforward Gain: Extra torque applied based on the current value of the specified type. These gains compensate for the delays caused by actions of the Compensator. The velocity feedforward applies a fraction of maximum torque based on the current velocity command. Acceleration feedforward similarly applies torque based on the current acceleration demands.

Following Error: Another name for Tracking Error (see below).

Gains: Parameters within the SSt servo drive's compensator that multiply the various errors and command values. The results of these multiplications are summed at various points to calculate the compensator output.

Loops: Control feedback paths within the compensator. The SSt servo drive has a position loop, a velocity loop and a vector torque controller (a sophisticated current loop).

Position Integrator: A device that sums the history of the tracking error over time. The use of this device within the SSt servo drive's compensator assures that the tracking error will be forced to zero over a short period of time when the integrator gain K_i is used.

Overshoot: A possible response property of a servo system- It is defined as: the maximum amount that a response goes beyond or "overshoots" a target before being forced back toward the target value.

Position Error: Another name for Tracking Error (see below).

Ringling: A response property- when the response cycles around the target value after a change in target or in response to an external disturbance.

Settling Time: There are various definitions for this response property, but the one used in this document is- The amount of time that is required for the response to reach its target value from the last change in that target (position or velocity). The response is considered to have reached its target value when it is within some pre-defined window: e.g. 2% of the move length, .001", 1 RPS, etc.

Stiffness: The amount of force (torque) applied divided by the position error distance (angle). Typically measured when the system is at rest.

Tracking Error: By definition, all systems that respond to a command signal exhibit some finite error with respect to the command. The instantaneous position error that occurs during SSt servo drive movement is referred to as "tracking" error; it refers to how well the SSt servo drive tracks the incoming steps. The SSt servo drive's high bandwidth means that this error will be small compared to other systems for any given command signal. (Note: Contrary to some manufacturer's claims, stepper motors also have continual tracking error. Their error, however, is either less than 3.6 degrees (two full steps) or essentially infinite, because beyond two steps of tracking error, the stepper motor will stall.)

Velocity Error: By definition, all systems that respond to a command signal exhibit some finite error with respect to the command. The difference between the commanded velocity and the measured velocity is the velocity error. Inside SSt servo drive, the commanded velocity is calculated by counting the number of input step pulses that have occurred over a period of time, and the measured velocity is calculated by counting the number of encoder counts that have occurred over a period of time.

THE SSt SERVO DRIVE COMPENSATOR (CONTROL ALGORITHMS)

The structure of SSt servo drive control loops is very simple. The loops are nested similar to a traditional analog servo system. Because of this structure, the basic procedure for tuning the SSt servo drive is generally non-interactive. A simplified schematic of the proportional + integral + velocity loop (PIV) compensator is shown below. The compensator also

The Tuning Stimulus functions as shown in the diagram below. A variable frequency, variable amplitude square wave reference is generated which can be routed to the input of the position, velocity or torque control loops. When the Tuning Stimulus is on, any external stimulus from the step and direction inputs (and the analog input in SSt servo drive Plus™) are ignored. When the Tuning Stimulus output is routed to the torque loop, the position and velocity control loops are rendered inactive.

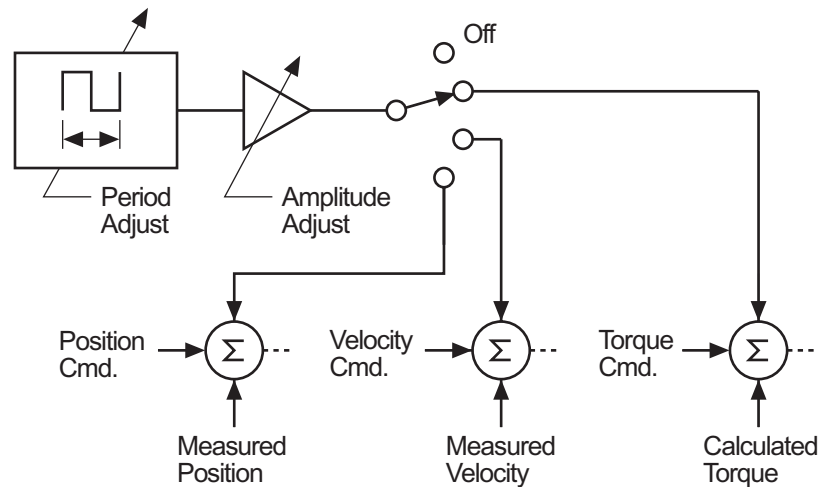

SSt servo drive includes a built-in function generator for stimulating the position, velocity or torque control loops for precise tuning.

Note: You should be careful when using the Tuning Stimulus. It can place extreme demands on your system especially if the period is short or the amplitudes are large. **YOU CAN BREAK YOUR MECHANICS AND/OR CAUSE A DRIVE SHUTDOWN (letting the axis “fly”) WITH THE TUNING STIMULUS IF YOU ARE NOT CAREFUL.**

You should follow the following recommendations to avoid this:

1. Don't use it in torque mode with an amplitude above 25% unless the total time the Tuning Stimulus will run is less than a few seconds.
2. Keep the amplitude of position and velocity stimuli small (a few degrees or a few hundred RPM) if you want to run them with a short period (i.e. 500ms or less). Larger amplitude stimuli can be used if the period is long (i.e. thousands of milliseconds).

One final note about the Tuning Stimulus: Because the stimulus is abrupt, SSt servo drive will respond in kind—attempting to follow the square wave as faithfully as possible. For all but the smallest amplitude stimuli, this will drive the SSt servo drive into saturated, “non-linear” operation.

To see the response indicative of what you will actually get, use a properly set up indexer/controller. In fact, you will probably see no overshoot when using your indexer/controller even though you have tuned the system for overshoot (given a square wave input). In addition, the settling time will be much faster when using an indexer/controller. The settling time in response to a 30i stimulus might measure 30ms, while the settling time from the end of a move controlled by the indexer/controller would typically be less than 5ms.

USING THE REAL-TIME REAL-TIME MONITOR PORT

The Real-time Monitor port is an analog output that lets you view with a normal oscilloscope the following parameters:

- Commanded Velocity
- Commanded Torque
- Measured Velocity
- Measured Torque
- Velocity Error
- Tracking Error (position error)
- Sine R (vector control reference)
- Other parameters, such as settling time, acceleration, reflected inertia, etc., can be measured or derived using the above selections

The Real-time Monitor port is updated approximately 2,000 times each second and displays the most recent value of the selected parameter.

The output of the port's range is 4V peak-to-peak centered around a 2.5 volt DC bias. In other words-it varies between 0.5 volts and 4.5 volts and will output 2.5 volts when the variable being displayed equals zero. (e.g.: a 2.5 volt output will be present when there is zero position error and you're viewing Tracking Error). A separate 2.5V reference pin is also provided at the diagnostic connector for use with instruments with differential inputs.

Important and Helpful Note: Many people don't seem to immediately realize the immense power of the Real-time Monitor port. Expert users, however, are nearly unanimous with regard to its indispensability. Do yourself a big favor and learn how to use and interpret the Real-time Monitor port parameters. You will leapfrog any poor system developer who does not have access to this type of information. If you like, you can call Teknic, and an applications engineer will be glad to invest as much time as you need to get familiar with the power of The Port.

SETTING UP YOUR OSCILLOSCOPE

To view the output of the Real-time Monitor port, connect your oscilloscope as shown below. (See the Diagnostic/Configuration Cable Diagram in the Installation section of this manual.)

Open SSt-QuickSet's™ main window and click on the Calibrate button. The output of the Real-time Monitor port will now output a 2V peak-to-peak 20Hz square wave.

Set your oscilloscope's trigger to NORMAL, sourced from the channel attached to the SSt servo drive, high frequency reject if available, the VERTICAL SENSITIVITY to 0.5V/division, the TIMEBASE SPEED to 10ms/division and adjust your VERTICAL and HORIZONTAL POSITION until the waveform is centered on your screen as shown below. Your oscilloscope's screen will now display the full range of the Real-time Monitor port. You should not need to readjust the VERTICAL SENSITIVITY or VERTICAL POSITION of your oscilloscope at any time when using this port. All future display adjustments should be set using the range field in the Monitor Port panel of the main window.

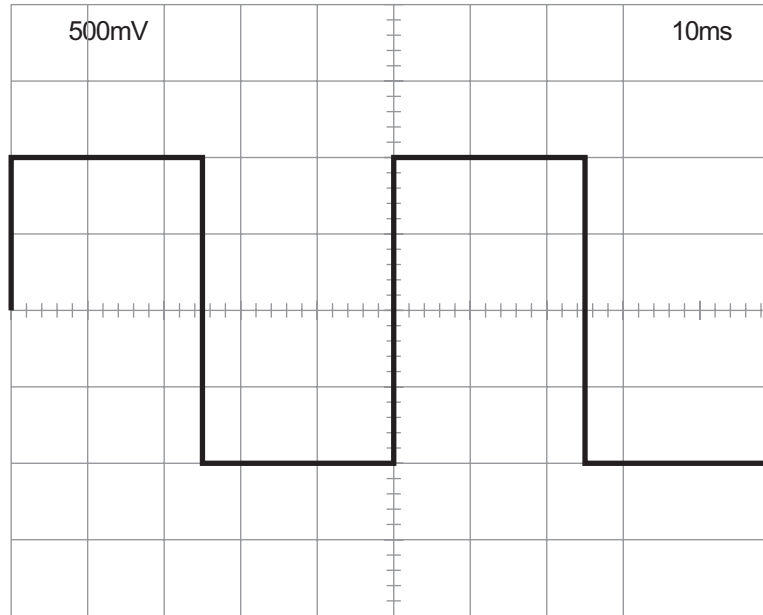

Your Oscilloscope screen should look like this when you are using the Real-time Monitor port's built-in calibrator and your oscilloscope's vertical position is adjusted properly.

For most of the measurements that follow you will want to use NORMAL triggering with the Real-time Monitor port. The only oscilloscope controls you will need to adjust when using the Real-time Monitor port will be the TIMEBASE SPEED, the TRIGGER LEVEL and/or the TRIGGER POLARITY. All other adjustments will be made with SSt-QuickSet™.

TUNING FOR PERFORMANCE

The following simple procedure walks you through manually tuning your SSt servo drive. The results of this procedure are a good compromise for a wide range of applications. If you wish to further optimize your system, the "Tailoring the Response to Your Application" section below will give you some tips on how to optimize your system for your machine's specific requirements.

SETTING UP FOR TUNING

- A. Connect the motor to its intended mechanical load and make sure that the shaft is free to move.
- B. Move the system to its mechanical center.
- C. If the use of limit switches is feasible on your mechanics, CONNECT THEM. If not, install a limit switch cheater plug as described in the Installation section above.
- D. If you're not using a Teknic-supplied SSt-CC controller cable which has a switch on the Enable~ line, you should install a simple switch in series with the Enable~ pin (pin 8 on the Controller connector)

and your indexer. This will allow for a fast and easy way to disable SSt servo drive, without the intervention of software. The tuning process requires disabling the drive at times, and the switch can also be used as a "kill" switch, if necessary. Toggling the switch will also clear any drive protection shutdowns that might occur.

- E. Open the User Units setup window and depress the Default button. (This step is not necessary but it does assure that the units shown on your screen are the same as the ones in this manual.)
- F. Connect an oscilloscope to the Real-time Real-time Monitor port and adjust the controls as described above.
- G. It will be helpful to you if you first read through this entire section before actually beginning the tuning process.

TUNING THE VELOCITY LOOP

1. Open the main window of SSt-QuickSet™ and depress the “1-Kv Tune” button in the Setups section. This will zero Kv, Kp and Ki gains and set up the Real-time Monitor port and the Tuning Stimulus.

Note: The axis should be free to turn ± 5 turns without hitting an obstruction in order to run this test. Call Teknic for special instructions if this is not possible.

[The Real-time Monitor port will be set to Velocity Error with a range of $\pm 1,000$ RPM (250 RPM/division) and the Tuning Stimulus will be set to inject a ± 750 RPM command signal into the velocity loop with a period of 500ms.]

2. Enable SSt servo drive.
3. Start the Tuning Stimulus by clicking on the “On/Off” button.

The indicator above the “On/Off” button should come on and stay on. If it does not stay on, the drive is not enabled; enable the drive and try again. Your oscilloscope should display the start of a square wave stimulus with an amplitude of ± 3 divisions.

Because the velocity gain, Kv, is set to zero, the motor will not yet respond to the velocity moves commanded by the tuning stimulus.
4. Begin to increase Kv: the motor should start to move.

Keep increasing Kv until you notice about 2% to 5% overshoot on your oscilloscope as shown in the figure below. Remember to hit ENTER to send your new value to the drive after modifying the form. Alternately, you may use the field entry accelerator to step the value up and down. Hit F1 (Help) for more details.

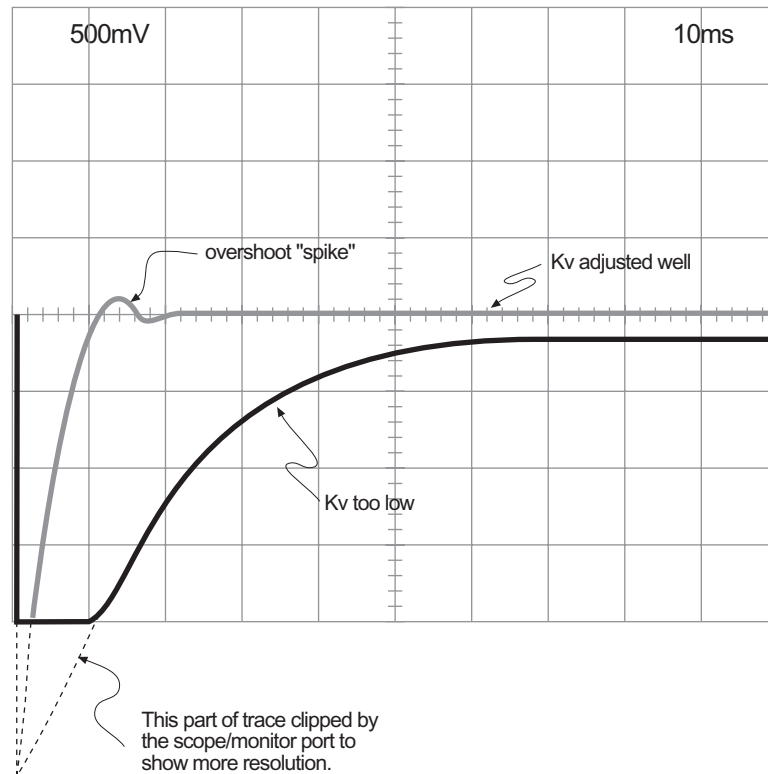

Typical Velocity Responses

Because you are viewing velocity error and not actual velocity, you will see response spikes and not square waves on your oscilloscope after you are done with this procedure. This is because you are viewing the difference between the square wave stimulus and the response of your SSt servo drive as it attempts to follow the abrupt changes. With Kv at zero, the motor will not move and you should see the step (square wave) stimulus on your oscilloscope. As you increase Kv, the square wave will change shape as shown below—at some point only spikes will remain. It is the "overshoot" of these spikes that you are trying to adjust.

Values for Kv usually fall between 2,000 and 50,000. (In 80 percent of systems, Kv falls between 10,000 and 30,000). So you should start around 2000 and increase in increments of around 4000 (i.e.: 2,000, 6,000, 10,000, etc.) until you bracket the correct response. Then go back and iterate in smaller steps until you see 2% to 5% overshoot.

If, during this procedure, a drive shutdown occurs due to an RMS limit, the motor may have been about to overheat. If this occurs, the stimulus period should be increased (this will require, however, that the motor turn farther during this procedure).

Tuning for a small overshoot usually works quite well. Sometimes, however, the system will exhibit extended ringing even at this low level of overshoot. If you detect more than a few cycles of ringing you should scale back the Kv gain until this is corrected⁶.

⁶ This usually indicates that there is a mechanical resonance in your system which will ultimately limit performance. Although you can "tune around" this resonance, your

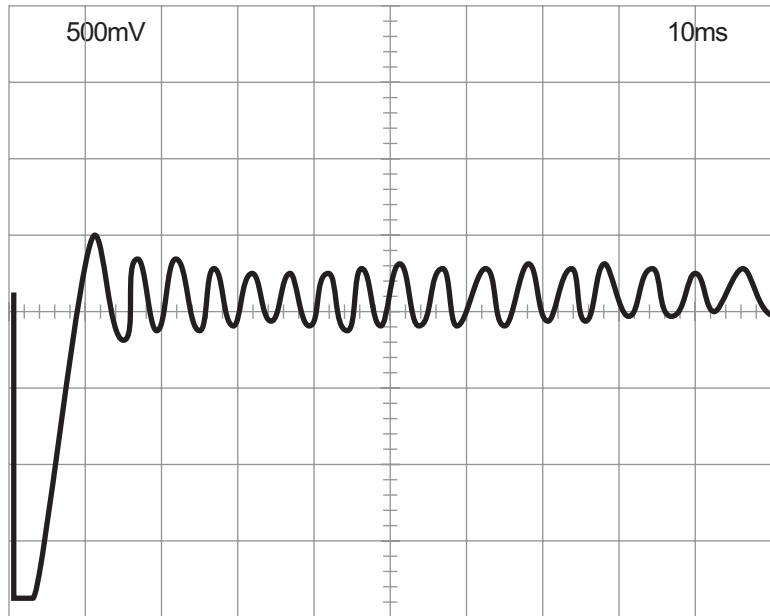

Unstable Velocity Loop Response (Ringing)

In general you should test the limits of K_v —increasing K_v beyond where you believe it is well tuned, there is little penalty for this (except for perhaps enduring some noise) and often it reveals that K_v can be tuned substantially higher. A common example of this often occurs when the load is belt driven—what appears like ringing during the rise time is actually belt “slap” that can be “tuned out” by increasing K_v .

5. Begin to increase K_{fv} , the velocity feedforward gain, until the “steady state” error (just before the next stimulus transition) is at a minimum. You may want to reduce the range of the Real-time Monitor port to ± 200 RPM to get a better view of this.

Values for K_{fv} usually fall between 0 and 10,000. So you should start around 100 and increase geometrically, i.e. 200, 400, 800, etc. until you bracket the correct response. Then go back and iterate in smaller linear steps until you see minimum steady state error as shown in the diagram below.

system performance will be enhanced if it is removed from the system. There may be several simple solutions to this problem, contact Teknic for details.

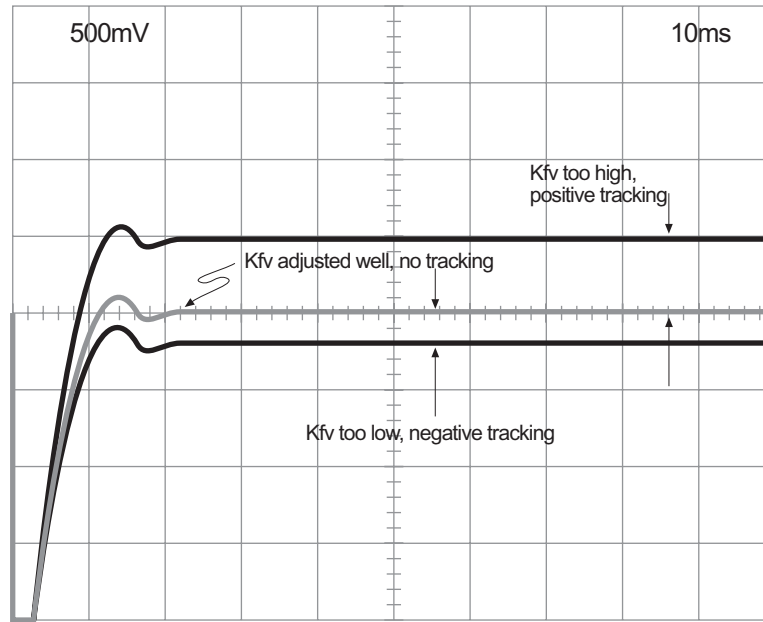

Velocity Feedforward Adjustments

Don't be surprised if your system requires little of no Kfv gain, this is often the case if the friction in your system is very low.

Note: Feedforward gains mathematically differentiate the incoming move profile from the indexer/controller and feed it to the torque loop. Therefore, if the pulse train from the indexer/controller has any of the following characteristics: update rate lower than 0.5ms, a discontinuous "notchy" profile, or if the number of steps per revolution is set to less than the SSt servo drive's quadrature counts per revolution setting, a noise disturbance will be transferred directly into the motor by the feedforward gains. This will tend to cause excessive torque usage and rough motion. Always turn on the RAS feature if this is the case to minimize this noise.

6. Stop the test by clicking on the "On/Off" button in the "Tuning Stimulus" section of the main window.

TUNING THE POSITION LOOP

7. Disable SSt servo drive and move the axis to its mechanical center (if it moved off during the previous procedure).
8. Click on the "2-Kp Tune" button. This will zero out the Kp and Ki gains, set up the Real-time Monitor port and "Tuning Stimulus". [The Real-time Monitor port will be set to Tracking Error with a range of ± 40 degrees (10 degrees/division) and the "Tuning Stimulus" will be set to inject a ± 30 degree command signal into the position loop with a period of 500ms.]
9. Enable SSt servo drive.
10. Start the "Tuning Stimulus" by clicking on the "On/Off" button.

The indicator above the "On/Off" button should come on and stay on. If it does not stay on, the drive is not enabled; enable the drive and try again. Your oscilloscope should display a ± 3 division high square wave edge.

Because the position gain, K_p , is set to zero, the motor will not yet respond to the position moves commanded by the “Tuning Stimulus”.

11. Begin to increase K_p : the motor should start to move.

Keep increasing K_p until you notice overshoot on your oscilloscope as shown in the figure below. Adjust K_p for approximately 5% overshoot.

Values for K_p usually fall between 1,000 and 25,000. (In 80 percent of systems, K_p falls between 7,000 and 16,000.) You should start around 1000 and increase in increments of 2000 (i.e.: 1000 3,000, 5,000, etc.) until you bracket the correct response. Then go back and iterate in smaller steps until the desired response is achieved.

AS YOU INCREASE K_p , THE AXIS MAY REACT QUITE VIOLENTLY. IF YOU THINK THAT YOUR MECHANISM MAY BE DAMAGED, REDUCE THE EXCITATION AMPLITUDE (i.e.: REDUCE THE TUNING STIMULUS AMPLITUDE FROM 30 DEGREES TO, SAY, 15 DEGREES).

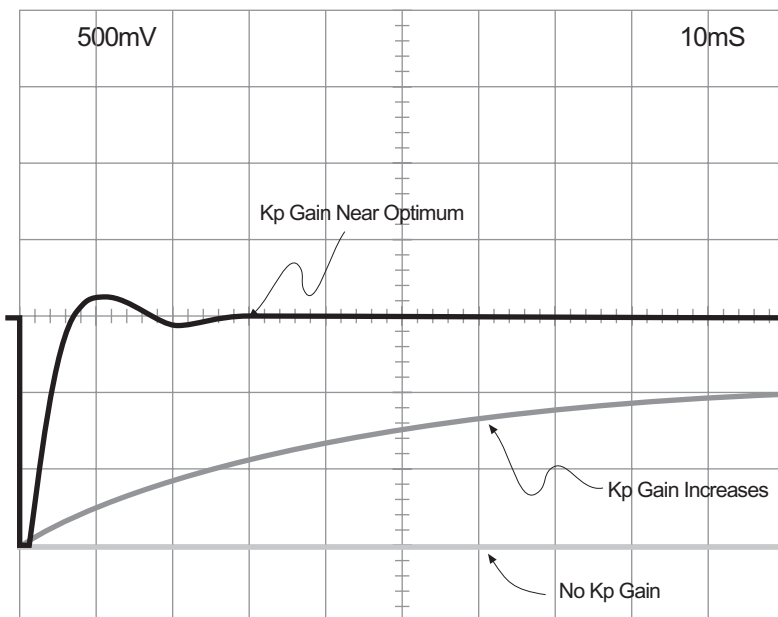

Tracking Error response as K_p is increased.

If, during this procedure, a shutdown occurs due to an RMS limit, the motor may have been about to overheat. If this occurs the stimulus period should be increased. If a shutdown occurs due to a Tracking Error it is probably because the K_p gain was set too high and very large overshoot and/or ringing occurred. If this occurs, reduce K_p . In either case make the appropriate adjustment, disable and enable the drive to clear the shutdown⁷, start the “Tuning Stimulus” and continue tuning.

⁷ This can also be done by double-clicking on the word “Ready” where it appears in the main menu bar, or by using the Reset Shutdowns command found under the Setup menu.

12. Stop the test by clicking on the “On/Off” button in the “Tuning Stimulus” section of the main window. (Alternately, if you have followed the tuning procedure from the start, and plan on continuing, you can leave the “Tuning Stimulus” running and proceed immediately to step 15.)

ADJUSTING THE INTEGRATOR

13. Click on the 3-Ki Tune button. This will zero the integral gain and set up the Real-time Monitor port and “Tuning Stimulus”. (The setup created by this button is identical to that of the “2-Kp Tune” button, except Kp is not set to zero. Therefore, if you have followed the tuning procedure from the start, there is actually no need to press this button now.)
14. Start the “Tuning Stimulus” by clicking on the “On/Off” button. The motor will move at this point.
15. Adjust the Ki integrator gain while observing the oscilloscope as before so the axis has maximum overshoot without any subsequent undershoot. More descriptively, once the response has overshoot the target value (center line) it should come back to the target without passing it in the other direction. If it does, reduce Ki until only overshoot occurs. Typically an axis will exhibit this behavior at about 20% overshoot.

Values for Ki usually fall between 10 and 3,000. (In 80 percent of systems, values for Ki will fall between 40 and 1,500.) So you should start around 10 and increase in increments of about 100 (i.e.: 10, 100, 200, etc.) until you bracket the correct response. Then go back and iterate in smaller steps until the desired response is achieved.

- 15a. [SSt-1500-Axx only] Increase the Knv IMT gain until the integrator overshoot is minimized.

The integrator gain (Ki) should be set to zero if you are using an SSt servo drive Plus™ as an analog servo amplifier.

ANTI-HUNT™

During the above tuning procedures you may have noticed that the motor began to “buzz” or “grind”. What is occurring is a low level limit cycle as the motor hunts between encoder ticks. This usually is not a problem, but it may be perceived as one by your customers (users) and should be avoided. For this reason, Teknic developed the Anti-Hunt™ feature. When in use, SSt servo drive uses a non-linear, fuzzy technique that helps quell the buzzing motion that can occur at zero speed with other servo controlled systems. In general, this allows the use of higher gains for stiffer and faster response without annoying buzzing.

To enable Anti-Hunt™, open the main window of SSt-QuickSet™ and turn the Anti-Hunt™ button to “On”.

If, after Anti-Hunt™ is invoked, the buzzing is still unacceptable, you may wish to reduce the gains of your loops. Reducing the Kv gain while increasing Kp and holding the product of Kp and Kv constant may stop the grinding without reducing performance.

ADJUSTING ACCELERATION FEEDFORWARD

The acceleration feedforward gain, K_{fa} , when used properly, will reduce the following error and the settling time performance of your system. It should be used if high performance contouring or point-to-point motion is required. If, however, you are using SSt servo drive for constant velocity or scanning applications, where smoothness is critical, it is recommended that you set K_{fa} to zero and you can skip the following tuning steps.

Depending upon how smoothly your indexer operates, there can be a negative aspect to using acceleration feedforward and you might want to avoid its use. The axis will get become loud when it is used and torque usage will increase dramatically. For this reason it is always advisable to turn on the RAS feature to smooth the incoming command. This will eliminate these problems.

The Tuning Stimulus is not an appropriate stimulus for adjusting K_{fa} because of its infinite commanded acceleration (remember, it's a square wave). In order to adjust K_{fa} properly, you must use an indexer with a smooth, linear acceleration ramp.

To do this, follow the following procedure:

16. Hook up your indexer to SSt servo drive. Set up the indexer for a trapezoidal move with the acceleration and maximum speed that will be used in you application. Program the indexer to repeat this move back and forth continuously as shown in the diagram below. The indexer's output can be verified by viewing "Commanded Velocity" using the Real-time Monitor port.

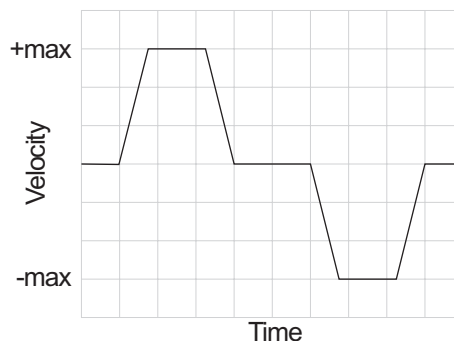

17. Trigger your oscilloscope such that you can view the response during the entire move. The easiest way to do this is to use the Real-time monitor ports "Sync pulse" pull-down menu setting it to "plus". Adjust the HORIZONTAL TIMEBASE so it corresponds to the length of the move as shown above. To be sure you have the scope set up right set the Real-time Monitor port to "Commanded Velocity" with a range equaling twice the maximum speed your indexer is commanding. Your oscilloscope should display a picture like above.
18. Set the Real-time Monitor port to "Commanded Torque" with the range set to the maximum number of ounce-inches that your SSt servo drive can produce.
19. Start the axis moving. (The SSt servo drive gains K_v , K_p , K_{fv} and K_i should be set using the previous steps of the tuning procedure as described above.)
20. View the Commanded Torque during the moves to ensure that the output stage of SSt servo drive is not saturating (i.e.: attempting to

- use more than the maximum available torque). The torque output should not exceed ± 3 divisions at any time during the move. If more than this torque is being used, reduce the acceleration of the move.
21. Switch the Real-time Monitor port to view "Tracking Error" and set the range to one tenth of the maximum velocity commanded by the indexer during the move.
 22. Set Ki to zero.
 23. Increase Kfa while viewing Tracking Error for the entire move. At some value of Kfa, the Tracking Error will be minimized.
 24. If you cannot detect any positive benefit when using a non-zero Kfa because the error was already so low you could not detect any improvement- be pleased. This means that you have a very high bandwidth, low error system. In order to set Kfa appropriately try reducing Kv and Kp to half their original value and repeat step 24. After you have completed this step restore Kv and Kp to their prior values.
 25. As before, switch the Real-time Monitor port to "Commanded Torque" with the range set to the maximum number of ounce-inches that your SSt servo drive can produce.
 26. View the Commanded Torque during the move with Kfa set to ensure that the output stage of the SSt servo drive is not saturating (The torque output should not exceed ± 3 divisions at any time during the move.) If more than this torque is being used reduce the acceleration of the move and repeat step 8.
 27. Restore Ki.

TAILORING THE RESPONSE TO YOUR APPLICATION

Every application has different requirements. Some applications demand absolute smoothness, but can trade off settling time and disturbance rejection. Others need minimum settling time, but can trade off some end of move oscillations provided that they are under a certain limit. For contouring applications, following error below a certain limit over the entire path may be the key parameter. The possible permutations of response requirements is infinite.

In general, the tuning procedures described above lead to a good compromise response, however, you may want to fine tune the gains to your needs. In order to do this you need to use your indexer/controller as the test command signal and not the internal "Tuning Stimulus" which only tests the step response.

Although step response tests can be illuminating, they are not representative of your real-world demands (which are almost always less stressful than step response tests). For this reason there is usually a good amount of latitude to both increase and decrease the gains from the values found in the procedures above.

Some examples: Increasing the gains makes the system "stiffer" and you might elect to do this if you are designing a machine for a contouring application where you expect only small, low frequency disturbances that will not excite an otherwise "hot" (underdamped) axis. Conversely, reducing gains makes the system motion smoother and you might do this for an image scanning machine, but this would reduce the disturbance rejection and point-to-point settling time.

KNOW YOUR OBJECTIVES

The first step in fine tuning an axis is to know, analytically, what your objectives are for the response. It is easy to spend a lot of time adjusting gains and the settings based upon subjective criteria that don't lead to the desired result. This seems obvious, but it is easy to get caught in this trap. Once you know what your response objective is, you can evaluate different tuning settings by measuring the response against the objective. SSt servo drive is one of the only products in the motion control marketplace that allows you to do this easily without expensive instrumentation. The following examples of fine tuning objectives should be illuminating:

A poor objective for a pick-and-place axis might be stated:

"The axis should move from point-to-point in minimum time."

A better stated objective for the fine tuning might be:

"The axis should move and settle to within 10 microinches as fast as possible from point-to-point when using a trapezoidal velocity move profile."

This objective can be further improved:

"The sum of the time to complete a 200 micro-inch move, a 0.1 inch move, and a 5 inch move should be minimized, with all moves considered complete when settled to within 10 microinches of the target when using the most aggressive trapezoidal and/or triangular velocity profiles that the axis can follow. Furthermore, this should occur under conditions of low output from the power supply caused by the AC line voltage dropping to 105V."

This may seem as if it is getting silly, but in actuality, the more qualified objective actually makes your job easier, keeps your marketing staff happy and ultimately keeps the customer happy because he/she knows exactly what can be expected from your machine.

A good objective for a contouring system might be:

"When traveling at 10 inches/second around a circle of 1" radius, the maximum error should be less than .005" while minimizing the mean squared tracking error over the entire circular path for both a 1 pound payload and 10 pound payload."

Of course any tuning objective must relate to your machine's overall performance objectives to be useful, but the tighter this objective can be specified, the faster and easier the fine tuning will be.

ADJUSTING FOR SMOOTHEST RESPONSE

There are certain applications that require a particularly smooth response. Usually these applications have requirements in terms of the maximum instantaneous velocity error that can be tolerated. There are two types of responses that can be troublesome in these systems: (1) fast, underdamped response to mechanical disturbances and (2) servo hunting or "jitter".

TUNING KV, KP AND KI FOR SMOOTH RESPONSE

In applications such as image scanning, the disturbance rejection of the system tuning needs to be reduced so that the response to mechanical

noise in the system will not be abrupt or at all oscillatory. The tuning procedure above will produce a slightly underdamped response characteristics that is not necessarily optimum for applications where the smoothest response is desired. (In a scanner, underdamped response can produce qualitatively poor images.) Underdamped response should generally be avoided wherever the human eye is used as the final measure of quality.

We describe here three levels of tuning for a smooth response, named level I, II and III. Level III is the smoothest. As you progress from level I to level III, however, you will be lowering the speed of response to disturbances (servo bandwidth) and the axis under control will feel "softer" with each level to which you proceed. In general, if you have a smooth, well-isolated and disturbance free mechanism you will want to use level II or level III tuning. If however, your mechanism is mechanically noisy or if the axis is likely to be disturbed by external forces, standard tuning or level I tuning may actually give you overall smoother response. Note: Level III should only be used if you have no concern that the axis may have some finite tracking error (this would be an application where you are concerned about velocity control only).

Level I:

Adjust Kv using the standard velocity loop tuning procedure except set Kv for the fastest rise time response that exhibits no velocity overshoot; Adjust Kp using the standard position loop tuning procedure except adjust Kp for the fastest rise time response that exhibits no position overshoot, then increase Ki until position overshoot is barely detectable.

Level II:

Adjust Kv using the standard velocity loop tuning procedure except set Kv for the fastest rise time response that exhibits no velocity overshoot. Then, do not follow the standard procedure for Kp, but instead adjust Kp using the velocity loop tuning procedure, increasing Kp, as before, until you observe the fastest rise time response that exhibits no velocity overshoot. After you have adjusted Kv and Kp in this manner adjust Ki using the Position loop tuning procedure for the fastest rise time response that exhibits no position overshoot.

Level III.

Follow the Level II procedure to adjust Kv and Kp. Set Ki to zero.

The best way to evaluate which tuning level is right for you is to look at the final result when operating your machine using the Real-time Monitor port and an oscilloscope. Alternately, you may have a specified velocity frequency spectrum envelope you must stay below. If this is the case, then you can use the Real-time Monitor port in Velocity Error mode as an input to an FFT analyzer with one caution: Ignore any response spikes at or around frequencies that are the speed in RPS times the line frequency (lines per revolution) or 4 times the line frequency of the encoder. Also ignore any response spikes above 1000Hz.

ELIMINATING SERVO JITTER

In certain applications the typical low level perturbations of an optimally tuned servo system can not be tolerated. These perturbations or "jitter" are a result of the servo responding to sensor noise (primarily quantization noise). Often this jitter, which typically sounds like a

grinding, is the limiting factor as to how high the gains, and hence the bandwidth, of the system can be adjusted. Most applications can tolerate a small amount of jitter especially if the frequency is low. For applications that are sensitive to jitter, a few things can be done to reduce it:

1. Use the SSt servo drive's Anti-Hunt™ feature
2. Reduce the compensator gains (perhaps using Level I, II or III tuning as described above).
3. Reduce the vector torque controller (current loop) gains.
4. Increase the line count of the encoder.
5. Increase friction in your system.

To see if the torque vector controller (current loop) is a source of noise in your system, set the Kv gain to zero and enable SSt servo drive. If the motor emits a grinding noise and you can feel any motion in the shaft in this mode you may want to reduce the Kii and Kip gains of the torque vector controller. Call Teknic for instructions on how to best do this.

ADJUSTING FOR MINIMUM SETTLING TIME (POINT-TO-POINT APPLICATIONS)

In general, the standard tuning procedure will optimize Kv and Kp for point-to-point applications. You may however be able to squeeze a little more performance out of the system by increasing Kv further. To do this repeat the standard tuning procedure except tune Kv for approximately 15% overshoot. If the response rings heavily when you try to do this (more than two cycles before being damped out), reduce Kv until you see less than two cycles of ringing in the response waveform. Now adjust Kp following the procedure. (Usually Kp will be higher than it is was when set with the nominal procedure.)

Turn on Anti-Hunt™

Leave Kfv alone.

Set Ki to zero and follow the procedure for setting Kfa.

The integrator gain Ki, and acceleration feedforward gain Kfa, however, should be tuned using your indexer/controller as the stimulus. To do this, set up your indexer/controller for the most aggressive move that will be made using the SSt servo drive being tuned. Open the main window of SSt-QuickSet™, select Tracking Error from the Real-time Monitor port's pull down menu. Enter a position range into the range field equal to four times your position settling criteria. Trigger your oscilloscope, if possible, from a signal from your indexer/controller that indicates that the move profile is complete.

Set up your indexer to repeat this move back and forth on a periodic basis (e.g. one second). Connecting a thermostat to the motor as described in the "Installation" section of this manual is a good added protection for ensuring the motor does not overheat. Adjust your oscilloscope to view the Tracking Error at the end of each move. Now adjust Ki until the settling time is minimized. (If you have set the Real-time Monitor port as described above, one large division on your scope will represent your settling time criterion. Settling time will then be the time it takes for the response to stay below one oscilloscope screen division from the end of the move profile.) After you have done this, adjust Kfa to see if you can further reduce this settling time. (Kfv can

also be adjusted, but rarely has a positive effect unless your system has a significant amount of viscous friction.)

NOTE: This procedure will not work properly if the acceleration or maximum velocity demand from your indexer/controller are too aggressive for the load. To check if this is the case, select Commanded Torque from the Real-time Monitor port's pull down menu. Enter the maximum rated torque for your SSt servo drive into the range field and view the output during the same move sequence used above to tune Ki and Kfa. The torque should stay below maximum (four oscilloscope screen divisions) during the deceleration portion of the move.

TROUBLESHOOTING YOUR MACHINE

HOW TO USE THIS SECTION

Today's sophisticated automation technology is a symphony of interrelated subsystems. Mechanical systems are comprised of at least several separate elements: slides, bearings, couplings, belts, gears, screws, and more. The mechanical relationship between the machine's load and the motor is governed by these mechanics, however, the relationship is a complex combination of both linear and nonlinear elements. Electrical systems are similarly complex. SSt servo drive, used in conjunction with SSt-QuickSet™, is a powerful tool to help you overcome all this complexity and get your machine performance optimized as quickly as possible.

Most problems encountered during the design of an SSt servo drive-based system are due to one of a few basic causes: incorrect wiring, misconfiguration of drive parameters, mechanical problems, operation beyond original design objectives (or under-specifying the system), and indexer/controller software problems. Unfortunately, there are many symptoms to these underlying problems, and also many variations of each problem. Determining the root cause of a problem can be difficult if a methodical procedure is not used.

Fortunately, with the SSt servo drive's Real-time Monitor port function and the following compilation of every problem we, and our many Beta-site customers, have ever encountered, you should be able to solve any difficulty with relative ease.

To use this section, first look at the boldface headings on the next page and find the general description of the problem you are encountering. Then go to the page(s) indicated for more questions/symptoms to help you further narrow down the possibilities. Finally, when you have determined the cause of your problem, one or more possible solutions are presented. Often, helpful hints are also provided to help you further optimize the performance of your machine.

Finally, if you encounter any problems you can't quickly solve using this section, or have any questions, or would like some personal assistance in any way, please don't hesitate to call Teknic.

PROBLEM TABLE OF CONTENTS

DRIVE SHUTS DOWN (GREEN LED BLINKS SLOWLY)	77
Tracking Error Shutdowns Occur	77
RMS limit shutdowns occur and/or Motor Runs Hot	79
I/V shutdowns occur	85
LACK (OR PARTIAL LACK) OF MOVEMENT	88
Motor Will Not Move.....	88
MOVEMENT NOT SMOOTH	92
Axis Jerks at End of Move	92
Axis jerks at beginning of moves	95
Motion erratic (“jerky”) while moving at constant velocity	96
Large velocity/torque ripple or “cogging” is evident	97
MOVE LENGTH INCORRECT/UNREPEATABLE	98
Motor shaft moves wrong, but repeatable, distance.....	98
Motor shaft moves an unrepeatable distance	99
Load moves an incorrect, <i>unrepeatable</i> distance	102
Motor “walks” when no step pulses are given.....	103
TORQUE SEEMS LOW	104
Motor moves but does not have full torque	104
Motor loses torque (or performance degrades) after running ..	106
MISCELLANEOUS (LOW PROBABILITY PROBLEMS)	108
Axis “sings” or “whines”	108
Limit switches don't work	110
Encoder error shutdowns occur.....	111
Drive resets when motor attempts to move	114
Thermal protection Shutdowns occur	115

DRIVE SHUTS DOWN (GREEN LED BLINKS SLOWLY)

TRACKING ERROR SHUTDOWNS OCCUR

SYMPTOM SUMMARY

1. Does the commanded acceleration/velocity request more power than is available?
2. Is the commanded velocity beyond the motor's upper limit?
3. Is the torque output reduced?
4. Is there a mechanical obstruction, or binding of the axis?
5. Is the SSt servo drive tuned properly?
6. Is the tracking error limit set too low?

COMPREHENSIVE ANALYSIS

1. Does the commanded acceleration/velocity request more power than is available?

Check the Trq Saturation and Volt Saturation LEDs in SSt-QuickSet's™ main window. If they light up during any moves sent from the indexer, you are asking for a move that exceeds the system's capabilities. (Note: Torque saturation may be normal if you are using any of the SSt's torque fold-back modes.)

Solution: If the Trq Saturation LED is lighting, change your indexer/controller's settings to reduce the acceleration demand (assuming the SSt servo drive is optimally tuned). Call Teknic if you want an estimate of the maximum acceleration and velocity for your application. If the Volt Saturation LED is lighting reduce the maximum velocity or torque or both.

Note that other solutions may be applicable. Better tuning and/or a better (more jerk-limited) command may eliminate torque saturation. Improved gearing may also help dramatically. A higher voltage power supply (up to 75VDC) may eliminate voltage saturation. Check the voltage with a scope (at the drive) with an oscilloscope.

2. Is the commanded velocity beyond the encoder's upper limit?

Look at the Overspeed LED during the move. If it comes at anytime during the move, the commanded velocity is too high or the Encoder Max Speed parameter is set wrong.

Solution: Change your indexer's settings to reduce the maximum velocity (steps/sec) or change the Encoder Max Speed parameter setting to an appropriate value.

3. Is the torque output reduced?

A potential cause of tracking error shutdowns is reduced torque output of a SSt servo system. When this occurs, the SSt servo system does not have enough torque to keep up with the commanded move profile and falls

behind. The loss of torque can occur for several reasons. For diagnostic procedures and solutions see the “Motor moves, but does not have full torque.” and “Motor loses torque (or performance degrades) after running” sections.

4. Is there a mechanical obstruction, or binding of the axis?

Disable the SSt servo drive and try rotating the axis by hand. For best results, turn the power transmission element closest to the motor shaft (e.g.: a coupling, pulley, screw, etc.) If the axis is clamped, obstructed or binds this is probably the problem. It is also likely that the RMS limit shutdown will occur when you attempt to move the axis with the SSt servo system if the mechanics are not free to move.

Solution: Remove the obstruction or free up the binding.

5. Is the tracking error limit set too low?

The tracking error limit (accessed via the “Inputs and Limits” window under the Setup menu) is intended to be used as a safety shutdown mechanism if the difference between the commanded position and the actual position becomes great due to a mechanical obstruction or failure. The lower the tracking limit alarm is set the faster the shutdown response will be under these conditions. However, if the limit is set too low, nuisance trips will occur.

Solutions: **(a)** Set the tracking error to an higher level which will still protect the system. If nuisance trips still occur, **(b)** empirically find the appropriate value for the tracking limit by viewing the tracking error during your machine’s normal operation. To do this, select “Tracking Error” for the Real-time Monitor Port output variable and operate the machine as you normally would. Adjust the TIMEBASE of the scope and the range of the monitor port so you can see the tracking error over an entire machine cycle. (If you have a digital oscilloscope, “envelope mode” or “infinite persistence” is very helpful for this test.) Then set the tracking error limit to a value safely above the maximum tracking error ever observed. (2x-4x is common.)

6. Is the SSt servo drive tuned properly?

If the SSt servo drive is not tuned properly, its response can have a substantial lag causing the tracking accuracy to be reduced during moves. If this is the case, tracking error shutdowns may occur.

Solution: Follow the tuning procedure listed in the “Optimizing Performance” section of the SSt user manual.

RMS LIMIT SHUTDOWNS OCCUR AND/OR MOTOR RUNS HOT

SYMPTOM SUMMARY

1. **Do any of the problems listed in the “Motor moves normally but does not have full torque” and/or “Motor loses torque after running” sections exist?**
2. **Does the mechanism have high stiction (start up friction) with a belt (or cable) drive?**
3. **Does the mechanism have high viscous or static friction?**
4. **Does the application call for continuous high speed operation?**
6. **Is the SSt servo drive poorly tuned?**
7. **Is there a short in the motor windings?**
8. **Is the Indexer/Controller’s profile discontinuous?**
9. **Does the application require more RMS torque than expected?**
10. **Is the RMS limit set too high?**

COMPREHENSIVE ANALYSIS

All motors have a maximum operating temperature. The maximum safe temperature is usually determined by the maximum temperature of the wire in the windings, but can also be limited by the magnetic material in the rotor and/or the maximum operating temperature of any electronics in the motor. Teknic standard motors, supplied as part of a SSt servo drive system should not be operated such that the case temperature is allowed to rise above 75°C.

A motor can run hot for three principal reasons: (i) The application requires more torque than the motor can deliver continuously and/or the motor does not have a good thermal path to remove heat, (ii) The motor is damaged, or (iii) The Vector Torque control (sinewave commutation) is not aligned (i.e.: is out of phase) with the rotor (this causes some or all of the current to heat the motor without producing torque). The last reason is also the cause of reduced torque output so you should ask the following question:

1. **Do any of the problems listed in the “Motor moves normally but does not have full torque” and/or “Motor loses torque after running” sections exist?**

Pertinent questions listed under “Motor moves, but does not have full torque”:

- Is the drive-motor cabling correct and intact?
- Are the commutation sensors properly wired?
- Was the proper configuration file loaded?
—or— Is the SSt servo drive properly configured to the motor?
- Is the R/O number set incorrectly (off by more than 20% of the motor’s nameplate R/O value)?

- Pertinent questions listed under “Motor loses torque after running”:
- Is the drive-motor cable loose or does it have intermittent connections or shorts?
- Have the encoder signals been routed to an indexer/controller with low impedance inputs?
- Is the motor cable length excessive?
- Is the encoder slipping on the motor shaft?

Read these sections listed above and follow the diagnosis procedures.

2. Does the mechanism have high stiction (start up friction) with a compliant (springy) transmission element drive?

If you have a mechanism that has considerable compliance (often occurs in tangential belt drives, very long screws, rubber couplings, etc.) and you have high static friction or stiction (start-up friction from plain linear bearings, worm gears, linear bearing seals, etc.), extra torque may be used continuously at standstill. This occurs when the load stops near but not at the required position and “sticks” there. The SSt servo drive responds by adding torque until the *motor* is at the exact position commanded, but, because the load is “stuck”, instead of moving the load it just stretches the compliant transmission element. A continuous torque is then required to maintain that position since the SSt servo drive works to “wind-up” the compliance in the transmission, and this torque will raise the temperature of the motor above what would normally be required for the application itself.

To diagnose the problem, set up the Monitor Port to display Commanded Torque and set the range to one half of the motor’s capability (e.g.: 80 oz-in for a 160 oz-in motor). Hook up your oscilloscope and set it up using SSt-QuickSet’s™ “Calibrate” button. Have your indexer/controller move the axis back and forth a few times while viewing the torque on the oscilloscope. If you see that the SSt servo drive is still commanding torque after the moves are complete, the stretch/friction is probably the problem. **Hint:** The torque commanded will not usually be consistent and will change sign based upon the direction of the move.

Solutions: **(1)** [PREFERRED] Remove the source of the friction. **(2)** Use a gearbox on the motor if you can tolerate the cost and speed reduction. **(3)** Use a larger motor. **(4)** Use Move Done Torque Foldback with the foldback torque set to a small value (such as 5% of the motor’s peak torque capability.) When the Move Done qualifiers are met at the end of each move, the torque will fold back to this value. This will allow the motor to move off its commanded position enough to release the spring load. This will not change the accuracy of the load position (it was already inaccurate to some degree because of the windup) but it will cause some tracking error at the motor.

3. Does the mechanism have high viscous or static friction?

High friction, beyond what is expected and designed for, can cause excessive RMS torque usage especially if the long moves or continuous speed operation are common in the application. This friction can come from excessive lead screw preload, worn bearings, linear seals on actuators, belt scrubbing, etc.

You can use the SSt servo drive to see exactly what friction is in your system by using the Monitor Port. Set up the Real-time Monitor Port to

display Commanded Torque and set the range to the motor's full capability (e.g.: 160 oz-in for a 160 oz-in motor). Hook up your oscilloscope and set it up using SSt-QuickSet's™ "Calibrate" button. Have your indexer/controller make long back and forth moves at top speed (or run at a constant speed, if applicable) while viewing the torque on the oscilloscope. During the constant speed portions of the move, look at the torque used. Is it what you expected? To find out if the friction is primarily viscous or static, reduce the speed to half of top speed. If the torque used during the constant speed portion of the moves has been reduced significantly, then the friction has a significant viscous portion⁸. Viscous friction is caused by fluid flow or plastic deformation (oil being pumped in a gearbox, linear seal deformation, belt tooth deformation at speed, etc.) while static friction is usually caused by sliding surfaces (bearings, nut preload, sliding seals, etc.).

Solutions: **(1)** [PREFERRED] Remove the source of the friction, if excessive. **(2)** Use a gearbox on the motor if you can tolerate the cost and speed reduction. **(3)** Use a larger motor. **(4)** Increase the thermal capability of the motor with one or more of the following methods: blowing air over the motor (this has a dramatically beneficial effect); using a more substantial mounting (heavier bracket, plate, etc.) to the machine frame; using thermal heat sink grease to mount the motor and the motor bracket to the frame. If you do this you will have to increase the RMS limit within the SSt servo drive (and this may require different mounting or even forced air cooling in some situations). Contact Teknic for information on how to do this.

4. Does the application call for continuous high speed operation?

Even though the SSt servo drive's vector torque control is the most efficient method for running motors at high speed, the physical nature of motors causes them to be less efficient when operated at higher speeds, and wasted energy in a motor is converted into heat. For this reason, the continuous torque capability of the motor is reduced as speed increases, and the motor will heat up more than it would when using same torque at a lower speed. ALSO NOTE: It is not unusual for a system to have more friction than expected (especially viscous friction, which you may not notice when you move the mechanics slowly by hand). Therefore you should follow the procedure above under "Does the mechanism have high viscous or static friction?" to check this as well.

If the friction in your system is as low as you can make it and you are still having trouble running the motors at speed, then you can pursue the following **solutions**: **(1)** Reduce the motor speed by decreasing the power transmission's effective gearing ratio. (Contact Teknic to have the overall effect of this simulated.) **(2)** Increase the thermal capability of the motor with one or more of the following methods: blowing air over the motor (this has a dramatically beneficial effect); using a more substantial mounting (heavier bracket, plate, etc.) to the machine frame; using thermal heat sink grease to mount the motor and the motor bracket to the frame. **(3)** Use a motor with lower losses at high speed (contact Teknic for this special requirement.)

⁸ To calculate the viscous and static friction subtract the torque at half top speed from the torque at top speed. Divide the result by the top speed and divide again by two. This result is the viscous friction reflected at the motor shaft in (oz-in/speed) units. To calculate the static friction multiply the viscous friction by the top speed and subtract this from the commanded torque at top speed. The result is the static friction torque.

5. Is the motor thermally enclosed or otherwise thermally isolated?

The torque capability of a motor is directly affected by how well wasted heat energy is drawn away from it. Teknic's standard motors have been rated for operation in free air, and most other motors are rated in free air, but attached to a heat plate. In either case, if they are enclosed without an adequate path for removing the heat, their continuous torque output capability will be reduced. (Conversely if they are cooled by air or heat sinked, their continuous torque output capability is increased.)

If you have mounted the motor in an enclosed area on plastic, fiberboard or other material with a low thermal conductivity, or mounted it at only the screw points (by using spacers, washers or a spider type mounting) then you are likely to have a problem if you are using the motor near its rated continuous limit.

Solutions: **(1)** Change the motor mount to Aluminum. (The 6061 alloy is both strong and has good thermal conductivity.) **(2)** Mount the motor face to a tight fitting bracket or plate. **(3)** Use thermal heat sink grease between the motor and its mount and also use it between the motor mount and the machine frame. **(4)** Remove, perforate, or otherwise "open" the enclosure around the motor. **(5)** Blow air over the motor with a fan (this has a dramatically beneficial effect).

6. Is the SSt servo drive poorly tuned?

If the SSt servo drive gains are set poorly, causing a heavily underdamped response, the RMS torque used will increase above what is necessary to make the move. This is because heavily underdamped tuning causes the motor to oscillate about its commanded position. Extra torque is used each time the motor is pushed ahead or behind the target. Normally, if the tuning is slightly underdamped, as suggested in the tuning procedure described in the "Optimizing Performance" section of the SSt user manual, this is not a problem.

Another source of RMS shutdowns and motor overheating is due to tuning is the excessive use of feedforward gain(s). The feedforward gains mathematically differentiate the incoming move profile from the indexer/controller and feed it to the torque loop. Therefore, if the pulse train from the indexer/controller has any of the following characteristics: update rate lower than 0.5ms, discontinuous "notchy" profile (see the section: "Is the Indexer/Controller's profile discontinuous?"), or if the number of steps per revolution is set below the encoder resolution, a noise disturbance will be transferred directly into the motor by the feedforward gains. Torque is used both to create these disturbances as well as to correct them, leading to excessive torque usage.

The feedforward gains, K_{fa} and K_{fv} , are set from *SSt-QuickSet's*TM main window. Note, however, that an *implicit* velocity feedforward gain also exists in the SSt servo drive's control loops, with a magnitude equal to the K_v gain being used. If any of the undesirable indexer/controller characteristics (described above) exist, you will get smoother motion by eliminating some, or all, of this implicit feedforward.

To diagnose the problem, set up the Monitor Port and set the range to the motor's full capability (160 oz-in for a 160 oz-in motor). Hook up your oscilloscope and set it up using the *SSt-QuickSet's*TM **Calibrate** button. Have your indexer/controller move the axis back and forth a few times while viewing the torque on the oscilloscope. For trapezoidal velocity profile moves (the most common), the torque should have three

rectangular regions during the move (accelerating, running and deceleration). Although you should expect to see some “hash” on the torque profile as the SSt servo drive corrects for minor disturbances, this hash should be no more than about a half division on your oscilloscope’s screen (1/8 full torque). If the “hash” is greater than this, then poor tuning is probably part of your overheating problem.

Solution(s): **(1)** Follow the tuning procedure described in the “Optimizing Performance” section of the user manual to verify that the tuning was performed correctly. **(2)** Set the SSt servo drive’s RAS feature to at least 4ms or greater. This will reduce the RMS torque usage (and make the motion smoother and quieter.)

7. Is there a short in the motor windings?

If the motor was severely overheated at some point, turns within the motor windings could be shorted due to insulation failure. (This is unlikely if the SSt’s RMS limit setting has been set correctly at all times.) If this has occurred, the motor will continue to overheat *even when operated within its normal limits*. In addition, the situation will continue to get worse because the extra current drawn by the short will “spot heat” the winding causing more shorts.

When this problem is pronounced an unhooked motor will feel especially lumpy and the phase-to-phase resistance will vary more than 15% from R-S, S-T and T-S. However, if only one turn is shorted you will have to follow the following procedure find it: Disconnect the motor and spin its shaft with another motor using a belt, coupling, etc. Spin the shaft at 1,000 RPM and measure the generated output voltages between each of the phase leads (R-S, S-T and T-R) Normally, the phase voltages will be within 2% of one another. If the voltages vary by more than 2%, there is probably a problem. Also check for heating of the motor being spun. This should be negligible. If the motor case temperature rises noticeably when being spun by another motor, a shorted winding exists.

Solution: Replace the motor.

8. Is the Indexer/Controller’s profile discontinuous?

A discontinuous profile can cause excessive heating by requiring excessive acceleration demands. For a discussion of the diagnosis and solutions to this problem see the question “Is the Indexer/Controller’s profile discontinuous?” under the section “Axis jerks at the end of the move”.

Solution: Set the RAS to as high a level as possible to smooth and jerk limit the incoming profile.

9. Does the application require more RMS torque than expected?

This could be due to a number of factors, including: More inertia than expected; more friction than expected; higher gravitational loading than expected; higher performance demands than were originally designed (i.e. once the system was working to the original specification, someone said “Now look at how fast I can make it go!”).

To diagnose this, use the setup described under the section: “Does the mechanism have high viscous or static friction?” and view the commanded torque during the operation of the application. Is the torque what you expected? Call Teknic to have a simulation run for your current mechanics/application if anything has changed since a simulation was run or if this is a new application.

10. Is the RMS limit set too high?

The RMS torque limit must be set for the maximum continuous torque rating of the motor or the SSt servo drive, whichever is less. Teknic standard motors come with configuration files with the appropriate RMS limit. If you are using a custom motor, you should use an RMS limit that is equal to the motor's continuous current limit divided by 23A. This fraction, multiplied by 100 is equal to the percentage that should be entered into the RMS Limit field of *SSt-QuickSet's™ Custom Motor Setup* window.

Note: If the RMS torque limit is set too high, it will *allow* the motor to overheat, but it is *not the cause* of the overheating.

It should also be noted that the RMS limit can also be set higher (i.e.: above 33% for Teknic supplied motors) if proper cooling measures are provided. Cooling can be accomplished using any combination of the following methods: **(1)** Blow air over the motor with a fan. **(2)** Mount the motor face to a tight fitting bracket or plate made of aluminum. (The 6061 alloy is both strong and has good thermal conductivity.) **(3)** Use thermally conductive compound (heat sink grease) between the motor and its mount and also use it between the motor mount and the machine frame. (also use a thermally conductive compound between the motor face and an adapter flange, if any). If you do use any of these methods to increase the thermal capacity and hence the appropriate RMS limit of the motor be sure to install a thermostat to the motor case to ensure that it does not exceed 75 deg. C⁹

⁹ If you are using a fan to cool the motor be sure to mount the thermostat on the side of the motor with the least amount of airflow.

I/V SHUTDOWNS OCCUR

SYMPTOM SUMMARY

1. Are the vector torque control gains, Kii or Kip set too high?
2. Are you using a regulated supply?
3. Does the power supply have too little output capacitance?
4. Is there a large inertial load that is being rapidly decelerated?
—or—
Is the load vertical or on an incline?
5. Does the motor have a shorted turn in one of its windings?
6. Is there an intermittent short or open in the drive-motor cable?

COMPREHENSIVE ANALYSIS

I/V protection shutdowns can occur for two reasons: (1) The supply voltage exceeds a maximum limit of 90VDC nominal (86VDC minimum trip point) or, (2) The instantaneous DC bus current exceeds 27A. If either of these situations occur the drive is disabled to prevent damage to the output stage.

1. Are the vector torque control gains, Kii or Kip set too high?

If you are using a standard motor supplied by Teknic, make sure that Kii and Kip gains are the same as the ones in the original configuration file for that motor. If you are using a custom motor contact Teknic to find the proper Kip and Kii values.

Solution: Set Kip and Kii to their proper values. Note that the factory settings assume the power supply voltage is 75VDC. If it's not, first set the supply voltage to 75V in the "Inputs and Limits" window. Then enter the factory Kip and Kii values (in the "Custom Motor Setup" window) and then set the power supply voltage to its correct value (SSt-QuickSet™ will adjust the Kip and Kii values to the appropriate values for your power supply.)

Hint: To view the Kii and Kip gains in a previous configuration file *without* downloading it into a SSt servo drive, disconnect the SSt servo drive diagnostic cable from your PC and load the file into SSt-QuickSet™. You can then view and/or print the configuration using "Configuration Report" (accessed via the "Setup" menu). You cannot, however, edit the file without the SSt servo drive on-line—it handles much of the error checking for the system.

2. Are you using a regulated supply?

Most regulated supplies have little or no capability to be back driven (i.e. to sink current instead of having current drawn from them). This back-driven situation occurs whenever a load is decelerated (or lowered in the case of a vertical axis) at all but the most modest rates. When back driving occurs, a typical regulated power supply's output voltage rises

very quickly. If the voltage exceeds 86VDC at any time the SSt servo drive will go into I/V protection shutdown.

Solution: Switch to a bulk linear type supply with a large output capacitance.

3. Does the power supply have too little output capacitance?

When decelerating a load (or lowering a vertical load), current may be pumped back into the supply because the motor is acting as a generator. This is known as regeneration current and it causes the output voltage of the supply to increase as its output capacitor(s) charge up. If the regeneration current raises the supply voltage above 84VDC, SSt servo drive will go into an I/V protection shutdown. Monitor the supply voltage when the machine is in operation. If it exceeds 84VDC at the time of the I/V protection shutdown, this is the source of the problem.

Solutions: (1) [Preferred] Add more capacitance to the supply output (this way you get all the energy back). **(2)** Add an automatic current shunt to the supply that turns on when a certain voltage is exceeded. **(3)** Reduce supply voltage.

4. Is there a large inertial load that is being rapidly decelerated?

—or—

Is the load vertical or on an incline?

When decelerating a large inertial load (or lowering a vertical load) substantial currents may be pumped back into the supply because the SSt servo drive motor is acting as a generator. This is known as regeneration current. If the regeneration current raises the supply voltage above 86VDC, SSt servo drive will go into an I/V protection mode. Monitor the supply voltage when the machine is in operation. If it exceeds 86VDC at the time of the I/V shutdown, this is the source of the problem.

Solutions: (1) [Preferred] Add more capacitance to the supply output (this way you get all the energy back). **(2)** Add an automatic current shunt to the supply that turns on when a certain voltage is exceeded. **(3)** Reduce supply voltage.

5. Does the motor have a shorted turn in one of its windings?

If the motor was severely overheated at some point, a turn or turns within the motor windings could be shorted due to insulation failure. If this occurs, the torque control loops may react unpredictably causing overcurrent (I/V) shutdowns. In addition, the situation will continue to get worse as the extra current drawn by the short will “spot heat” the winding causing more shorts.

When this problem is pronounced an unhooked motor will feel especially lumpy and the phase-to-phase resistance will vary more than 15% from R-S, S-T and T-S. However, if only one turn is shorted you will have to follow the following procedure find it: Disconnect the motor and spin its shaft with another motor using a belt, coupling, etc. Spin the shaft at 1,000 RPM and measure the generated output voltages between each of the phase leads (R-S, S-T and T-R) Normally, the phase voltages will be within 2% of one another. If the voltages vary by more than 2%, there is probably a problem. Also check for heating of the motor being spun. This should be negligible. If the motor case temperature rises noticeably when being spun by another motor, a shorted winding exists.

Solution: Replace the motor.

6. Is there an intermittent short or open in the drive-motor cable?

Intermittent shorts and opens in the motor phase wiring can wreak havoc with the torque control loops. Short duration current spikes result as the torque controller corrects for the instantaneous short or open circuit. These can cause the SSt servo drive drive to instantaneously overcurrent, thus causing an I/V protection shutdown.

Solution: Repair the drive-motor cable(s) and/or connector(s).

LACK (OR PARTIAL LACK) OF MOVEMENT

MOTOR WILL NOT MOVE

SYMPTOM SUMMARY

1. Has a protection shutdown event occurred (green LED blinks slowly)?
2. Are the limit switches disconnected?
3. Are normally-open limit switches being used?
4. Is the Enable~ line disconnected or set high?
5. Is the drive-motor cabling correct and intact (and plugged in)?
6. Does the motor have an open winding connection?
7. Is power applied?
8. Is the fuse blown?
9. Is there a mechanical obstruction or binding of the axis?
10. Is the SSt servo drive receiving the Step & Direction signals?
11. Was the proper configuration file loaded?
—or— Is SSt servo drive properly configured to the motor?
12. Are the Kv or Kp gains set to zero?
13. Are the torque loop gains Kii and/or Kip set to zero?

COMPREHENSIVE ANALYSIS

1. **Has a protection shutdown event occurred (green LED blinks slowly)?**
Check the source of the protection shutdown event by using SSt-QuickSet™. Continue debugging based upon the event reported.
2. **Are the limit switches disconnected?**
You can easily see if the limits are asserted by looking at the limit indicator “LEDs” in SSt-QuickSet’s™ main window. If both + Limit and - Limit are on it is likely that the limits are disconnected or the wrong type of switches are being used.
Solution: Connect the limit switches.
3. **Are normally-open limit switches being used?**
You can easily see if the limits are asserted by looking at the limit indicator “lights” in SSt-QuickSet’s™ main window. If both + Limit and - Limit are on and you are sure that the limit switches are connected properly, the wrong type of switch is probably being used. **Solution:** Change the switches to a normally-closed type.

4. Is the Enable~ line disconnected or set high?

You can see if the drive is enabled by looking at the status bar located just under *SSt-QuickSet's*TM main menu bar. If it says “Disabled”, the Enable~ line is not asserted.

Solutions: (a) Connect the Enable~ line to your indexer/controller. (b) Invert the polarity of the Enable~ line if the indexer/controller's enable output has a positive true polarity. (c) NOT PREFERRED— Permanently ground the Enable~ line.

5. Is the drive-motor cabling correct and intact (and plugged in)?

If you have constructed your own cable or modified a Teknic cable, this could be a problem. The motor not moving can be caused by motor phase, commutation sensor or encoder wiring problems. This means that all of the connections in the cable should be checked for shorts or opens.

Hint: If the cable has been modified, it is likely that a barb on a connector pin has been damaged and/or broken and this can cause a pin to be pushed out.

Solution: Use the “Check Sequence” button in the “Custom Motor Setup” window¹⁰ to test the cable. If it's not, repair the cable.

6. Does the motor have an open winding connection?

Check the resistance between all motor phases at the connector that plugs into SSt servo drive (R-S, S-T and T-R; pins 11, 12 and 13). Each winding should have the same resistance ($\pm 10\%$). None of the windings should be an open circuit. If any are open, this is the cause of the problem.

Solutions: (a) Check all intermediate connectors, terminals, bulkheads etc. (b) If the problem is in the motor itself, replace the motor.

7. Is power applied?

Look at SSt servo drive; the green status LED should be lit (on solid) or winking (blinking at a fast rate) and the red fuse indicator LED should be off. If both green and red LEDs are off, then no power is applied to the drive.

8. Is the fuse blown?

Look at the face of the SSt servo drive. If the fuse is blown, the red LED will illuminate when power is applied. Although it is possible for a fuse to blow due to high stress operation of SSt servo drive, this is unusual.

9. Is there a mechanical obstruction or binding of the axis?

Disable SSt servo drive and try rotating the axis by hand. For best results, turn the power transmission element closest to the motor shaft e.g. a coupling, pulley, screw, etc. If the axis is clamped, obstructed or binds, this is probably the problem. It is also likely that an RMS limit shutdown will occur when you attempt to move the axis if the mechanics are not free to move.

Solution: Remove the obstruction or free up the binding.

¹⁰ This window is accessed by first clicking once on the word “Online” on the main menu bar and then simultaneously pressing Control-Shift-M

10. Is the SSt servo drive receiving the Step & Direction signals?

To check that the indexer/controller is outputting step and direction signals, and that the wiring to SSt servo drive is intact, you can use the Real-time Monitor Port to view the “Commanded Velocity”.

Hook up an oscilloscope and use the SSt servo drive’s “Calibrate” button to set the vertical scaling and position. Trigger your oscilloscope using NORMAL mode. Set up the SSt servo drive’s Monitor Port to view Commanded Velocity. Set the Monitor Port range so it’s about 33% greater than the maximum velocity that your indexer/controller is programmed to deliver.

Set up your indexer/controller to repeat a typical move back and forth with a pause in between cycles of a couple of seconds. Start the indexer/controller. You should be able to view the incoming profile on the oscilloscope. If not, the wiring and/or the indexer/controller is at fault. (To get an idea of what a typical profile looks like, see the diagram under “Motor Jerks at the end of move” section.)

11. Was the proper configuration file loaded? —or— Is the SSt servo drive properly configured to the motor?

SSt servo drive drives normally come pre-configured to a motor bundled together in the same package. If, however, motor and drive pairs become confused and/or if someone has been using a SSt servo drive to experiment with or learn SSt-QuickSet™, then the configuration file may no longer match the motor.

Solutions: (a) If you are using a SSt servo drive system with a Teknic supplied motor and you are using it for the first time make sure you load the proper factory supplied configuration file into the SSt servo drive. **(b)** If you have previously set up a SSt servo drive with an identical motor and mechanics and have a known-good configuration file (that has worked properly in the past for this motor/mechanics) then load that file.

If you have started with a factory configuration file or other known-good configuration file, and the motor stopped moving after changes were made to the configuration, check that the R/O number and Encoder Counts per Turn have not been changed. Also check that the Kv, Kp, Kip and Kii gains are not zero. You can view and/or print the entire drive configuration easily by using “Configuration Report” under the “Setup” window.

Solutions: (a) Reload the proper factory file or other known-good configuration file. **(b)** Adjust the R/O number, Encoder Counts per Turn, Vector Reference, Kip and Kii to the proper values. (Note: To adjust the number of steps per revolution, do not use the Encoder Counts per Turn field in the “Custom Motor Setup” window. This is adjusted using the Step Position Resolution field in the “Inputs and Limits” window.)

Tune the drive, if necessary, using the tuning procedure described in the “Optimizing Performance” section of the user manual.

12. Are the Kv or Kp gains set to zero?

If the Kv gain is zero the motor will not move. If Kv is very low (less than 3,000) the motor may not move. If Kv is non-zero, but Kp is set to zero, the motor may move, although not repeatable, and it will have no holding torque. You can view and change these gains from SSt-QuickSet’s™ main window.

Solution: Follow the tuning procedure described under the “Performance Tuning” section of the user manual.

13. Are the torque loop gains Kii and/or Kip set to zero?

If these gains are set to zero the motor will not move.

Solutions: (a) For Teknic standard motors set Kii and Kip to their stock values by (i) Reloading the factory configuration file or, (ii) setting these gains manually to their normal factory preset values. To manually set the gains, look up the values of Kii and Kip in the factory configuration file *without* downloading it into a SSt servo drive. This can be done by disconnecting the SSt servo drive diagnostic cable from your PC and then loading the file into SSt-QuickSet™ Then view and write down the Kii and Kip gains using the “Custom Motor Setup” window. Reconnect the diagnostic cable and type the recorded Kii and Kip gains into SSt servo drive.

(b) For a custom motor, the torque loop tuning procedure must be performed. Contact Teknic for details.

MOVEMENT NOT SMOOTH

AXIS JERKS AT END OF MOVE

SYMPTOM SUMMARY

1. **Is SSt servo drive tuned too “soft”?**
2. **Is the Indexer/Controller’s profile discontinuous?**
3. **Is the commanded velocity beyond SSt servo drive motor’s upper limit?**
4. **Does the commanded acceleration/velocity request more power than is available?**

COMPREHENSIVE ANALYSIS

The axis sounds as if it is “slamming” at the end of the move profile and/or a large overshoot is detected either visually or by using the SSt servo drive’s Real-time Monitor Port. This is caused by a large error being present at the end of move (when the indexer/controller stops sending pulses to the SSt servo drive).

1. **Is SSt servo drive tuned too “soft”?**

If you have not gone through the tuning procedure described in the “Optimizing Performance” section of the user manual, for this specific mechanism, this would be a good place to start before you follow the remainder of this procedure. If any of the gains are set too low, the tracking error of the axis can easily become large by the end of the move, causing end-of-move jerk as the SSt servo drive corrects the built-up error.

2. **Is the Indexer/Controller’s profile discontinuous?**

Set up the SSt servo drive’s Monitor Port to view Commanded Velocity. Set the range to 33% higher than the maximum velocity that your indexer/controller is programmed to deliver. Hook up an oscilloscope and use the SSt-QuickSet’s “Calibrate” function to set the vertical scaling and position.

Set up your indexer/controller to repeat a *long* move back and forth with a pause in between of a couple of seconds. “Long” meaning that the move is the longest that your application will use. Trigger your oscilloscope using normal mode triggering so you can view the Commanded Velocity during the duration of the move. Turn on the “Sync Pulse” function (within SSt-QuickSet’s Monitor Port controls) to trigger your scope at the beginning of each move.

View your indexer/controller’s profile to make sure it is smooth. Run the move and look at the profile on the oscilloscope. The move profile should be smooth (trapezoidal, triangular, parabolic, etc.) with no step discontinuities in speed, i.e.: it should not jump instantaneously from one speed to another at any point in the profile. If these discontinuities exist they are the likely source of the problem.

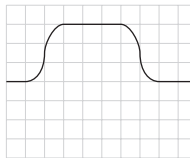
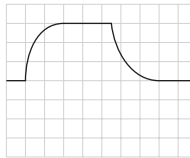
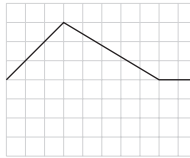
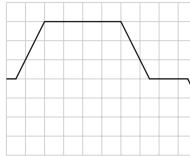
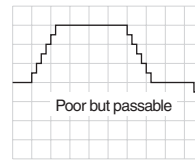
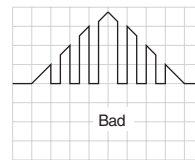
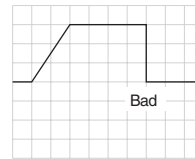
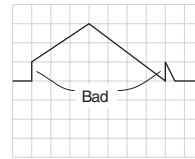
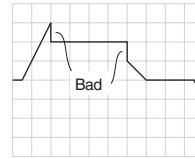
Examples of good
"smooth" profilesExamples of poor
"discontinuous" profiles

Typical Indexer/Controller Profile errors

Note that with the exception of profile "s" above, even the "good, smooth" profiles have discontinuities in acceleration (i.e.: jerk). This jerk is present wherever you see a sharp corner in the velocity profile, and will generally cause some instantaneous tracking error. If the system is well tuned, however, its effects will be unnoticeable without the aid of the Real-time Monitor Port.

Solutions: (a) Change the profile, use the SST's RAS (Regressive Auto-Splining) feature, (b) Repair the indexer's internal software, if applicable, (c) Change the indexer.

3. Is the commanded velocity beyond SSt servo drive motor's upper limit?

Look at the Over Speed LED in the main window during the move. If it comes anytime during the move the commanded velocity is too high (or the Speed Limit too low). Although SSt servo drive will limit the maximum speed of the motor automatically, tracking error will build up during the duration of the speed limiting, causing the motor to get significantly behind its commanded position. The jerkiness occurs as the motor tries to catch up at the end of the move and then "slams on the brake" to stop.

Solutions: (a) Change your indexer's settings to reduce the maximum velocity (steps/sec) (b) Increase the speed limit setting. This is rarely the solution with a Teknic standard motor, so call Teknic if you wish to try this option.

4. Does the commanded acceleration/velocity request more power than is available?

Check the Trq Saturation and Volt Saturation LEDs in SSt-QuickSet's™ main window. If they light during any moves sent from the indexer, you are asking for a move that exceeds the system's capabilities. (Note: Torque saturation may be normal if you are using any of the SSt's torque foldback modes.)

Solution: If the Trq Saturation LED is lighting, change your indexer/controller's settings to reduce the acceleration demand (assuming SSt servo drive is optimally tuned). Call Teknic if you want an estimate of the maximum acceleration and velocity for your application. If the Volt Saturation LED is lighting reduce the maximum velocity or torque or both.

Note that other solutions may be applicable. Better tuning and/or a better (more jerk-limited) command may eliminate torque saturation. Improved gearing may also help dramatically. Higher voltage power supply (up to 75VDC) may eliminate voltage saturation. Check the voltage with a scope (at the drive) with an oscilloscope.

Note: If you believe that your system should accommodate the acceleration rate being commanded—i.e.: it should have enough torque (based on a Teknic simulation or your own calculations)—you may have some other problem. See the “Motor moves normally but does not have full torque” section of Troubleshooting.

AXIS JERKS AT BEGINNING OF MOVES

SYMPTOM SUMMARY

1. Does the mechanism have a high amount of stiction?
2. Is there a discontinuity at the beginning of the move profile?

COMPREHENSIVE ANALYSIS

1. Does the mechanism have a high amount of stiction?

Check bearing condition and any other sources of binding.

Solution: **(1)** Repair or replace sticky or loose parts. **(2)** Improve the tuning, if possible.

2. Is there a discontinuity at the beginning of the move profile?

Check your indexer's profile as described in the "Axis jerks at end of move" section for discontinuities.

Solutions: **(a)** Change the profile, use the RAS feature or use a lower step rate with SSt servo drive configured for a lower step count per rev (This sometimes works around bugs within an indexer that occur at the higher pulse rates and accelerations.), **(b)** Repair the indexer's internal software, if applicable, **(c)** Change the indexer.

MOTION ERRATIC (“JERKY”) WHILE MOVING AT CONSTANT VELOCITY

SYMPTOM SUMMARY

1. **Do the mechanics have significant stiction and a compliant power transmission element?**
2. **Do you have a high inertial load connected through a mechanism that is not back-drivable?**

COMPREHENSIVE ANALYSIS

1. **Do the mechanics have significant stiction and a compliant power transmission element?**

Check the stiction (start-up friction) in the mechanism and also check the stiffness of the couplings, belts or extended shafts. The combination of stiction and compliance is very hard to control. **Solutions:** **(a)** Reduce the stiction, **(b)** Reduce axis compliance (increase stiffness—e.g.: use stiffer couplings (not helical type), less compliant belts, etc.), **(c)** De-tune the SSt servo drive (This will reduce overall speed and settling performance; contact Teknic for details on how to do this)

2. **Do you have a high inertial load connected through a mechanism that is not back-drivable?**

If the power transmission method employs a high pitch ACME screw or a high ratio worm drive and you have a heavy load the axis can easily get into a nonlinear limit cycle referred to as a “bind-hop”. Essentially, the inertia of the load is locking up part of the drive train, thus making effective control very difficult.

Solutions: **(a)** Change the ACME nut to a ball nut. **(b)** Reduce the pitch of the screw and add a belt or gearbox on the input, if necessary, to maintain the same overall gearing. **(c)** Change the worm gear to a lower ratio with a belt stage or conventional gearbox at the input, if necessary, to maintain the same overall gearing. **(d)** Remove the worm gear entirely and replace with a planetary, spur or harmonic (cycloidal) gear train. **(e)** De-tune SSt servo drive (This will reduce overall speed and settling performance, contact Teknic for details on how to do this).

LARGE VELOCITY/TORQUE RIPPLE OR “COGGING” IS EVIDENT

SYMPTOM SUMMARY

1. **Has the axis been properly tuned?**
2. **Is the mechanism damaged or worn, e.g. bent screw, bad bearing, etc.?**
3. **Has the motor been damaged (shorted turns in the windings) due to overheating?**

COMPREHENSIVE ANALYSIS

1. **Has the axis been properly tuned?**

If SSt servo drive has not been properly tuned to work with your mechanics, the resulting poor control fidelity can manifest itself as velocity ripple. This happens if the tuning causes SSt servo drive to be underdamped (oscillatory) at a low frequency and/or the tuning responds poorly to disturbances within the mechanism that naturally cause velocity ripple.

Solution: Follow the tuning procedure listed in the “Optimizing Performance” section of the user manual.

2. **Is the mechanism damaged or worn, e.g. bent screw, bad bearing, etc.?**

Disable SSt servo drive and move the axis by hand. If you notice excessive binding or sloppiness, this is probably the cause of the problem:

Solution: Repair or replace the mechanics.

3. **Has the motor been damaged (shorted turns in the windings) due to overheating?**

To check for a shorted turn, disconnect the motor and spin its shaft with another motor using a belt, coupling, etc. Spin the shaft at 1,000 RPM and measure the generated output voltages between each of the phase leads (R-S, S-T and T-R; pins 11, 12 and 13). Normally, the phase voltages will be within 2% of one another. If the voltages vary by more than 2%, there is probably a problem. Also check for heating of the motor being spun. This should be negligible. If the motor case temperature rises noticeably when being spun by another motor, a shorted winding exists.

Solution: Replace the motor.

MOVE LENGTH INCORRECT/UNREPEATABLE

MOTOR SHAFT MOVES WRONG, BUT REPEATABLE, DISTANCE

SYMPTOM SUMMARY

Motor moves only when given steps, and moves a repeatable distance each time but the distance is incorrect.

1. **Is the number of steps per revolution set incorrectly?**
2. **Is your indexer/controller outputting the correct number of steps?**

COMPREHENSIVE ANALYSIS

1. **Is the number of steps per revolution set incorrectly?**

You can check this by looking at SSt-QuickSet's™ status bar underneath the main menu bar.

Solution: Using the “Inputs and Limits” Window set the Steps/Rev field to the number you require.

2. **Is your indexer/controller outputting the correct number of steps?**

Check the indexer/controller's settings. Using an independent pulse counter verify that the number of steps/rev is correct. It may be helpful to view the commanded velocity using the procedure described under “Axis jerks at end of moves” to help find internal software bugs that might exist in the indexer/controller.

Solutions: **(a)** Change the indexer/controller settings and command program to output the correct distance. **(b)** Change the profile or use a lower step rate with the SSt servo drive configured for a lower step count per rev (this sometimes works around bugs within an indexer that occur at the higher pulse rates and accelerations), **(c)** Repair the indexer's internal software, if applicable, **(d)** Change the indexer.

MOTOR SHAFT MOVES AN UNREPEATABLE DISTANCE

SYMPTOM SUMMARY

1. Does the motor shaft move repeatably when measured using SSt-QuickSet's™ “Current Position” indicator?
2. Is the Ki gain set to zero?
3. Are the Step and Direction signals wired as specified?
4. Is SSt servo drive being disabled at the end of the move?
5. Is the indexer/controller outputting a repeatable number of steps?
6. Are the timing requirements for the Step and Direction signals being met?
7. Is the drive-motor cable loose or does it have intermittent connections or shorts?
8. Have the encoder signals been routed to an indexer/controller with low impedance inputs?
9. Is the motor cable length excessive?
10. Is the encoder slipping on the motor shaft?

COMPREHENSIVE ANALYSIS

To diagnose this problem, set up your indexer/controller to repeat a typical move back and forth with a pause in between of a couple of seconds. Using the “User Units” window, set the position display to show quadrature counts. Enable your drive and zero the “Current Position” display in the main window using the “oPos” button (or by double-clicking on the value). Start your indexer moving back and forth.

1. Does the motor shaft move repeatably when measured using SSt-QuickSet's™ “Current Position” indicator?

View the SSt servo drive's shaft position by viewing the position display in the main window. If this is moving repeatably to the correct position and back to zero, then the mechanics are slipping or binding and/or stretching. See the “Load moves an unrepeatable distance” section below. If the results of this test are unrepeatable, continue looking for the problem in this section.

2. Is the Ki gain set to zero?

Make sure the integrator (Ki gain) is being used, i.e. set to some positive value. This gain removes any error that occurs at the end of the move by integrating or “building up” a corrective torque over time until the error is eventually forced to zero. With this gain set to zero some steady state error will probably occur. (In some applications, where a small error can be tolerated at the end of moves, this gain is set to zero to improve the dynamic response of the system.)

Solution: Set the Ki gain to some non-zero value using the tuning procedure as defined in the Optimizing Performance section.

3. Are the Step and Direction signals wired as specified?

If the position display in the main window is not repeatable, and the Ki gain is set to some positive value, the problem is most likely the wiring for the Step and Direction signal lines. These high speed inputs also respond to conducted noise caused by improper grounding & shielding.

Solution: Explicitly follow the directions for wiring up these signals to the indexer/controller given in the “Installation” section of the user manual.

4. Is SSt servo drive being disabled at the end of the move?

If this condition occurs, SSt servo drive can possibly be disabled before the axis is fully settled, and/or mechanical disturbances can cause it to move off the intended stopping position. If this occurs, SSt servo drive will start from a new *unrepeatable* position each move.

Solution: Program your indexer/controller to keep SSt servo drive enabled at the end of the moves.

5. Is the indexer/controller outputting a repeatable number of steps?

Check the indexer/controller’s application program. Using an independent pulse counter, verify that the number of steps/rev is correct. It may be helpful to view the commanded velocity using the procedure described below under “Axis jerks at end of moves” to help find internal software bugs that might exist in the indexer/controller.

Solutions: **(a)** Change the indexer/controller application program. **(b)** **(c)** Repair the indexer’s internal software, if applicable, **(d)** Change the indexer.

6. Are the timing requirements for the Step and Direction signals being met?

Check the timing of the Step and Direction lines to insure they meet the timing requirements shown in the installation section of the user manual. The timing requirements are quite liberal and it is unlikely that they would be violated by any commercial indexer unless the pulse rate capability is extremely high (greater than 1MHz), but it is a possible problem. **Solutions:** **(a)** Change your indexer’s internal hardware or firmware, if applicable. **(b)** Change your indexer. **(c)** Send the Step and Direction signals through pulse shaping circuits.

8. Have the encoder signals been routed to an indexer/controller with low impedance inputs?

If the encoder signals have been routed to a indexer/controller and are too heavily loaded they can have marginal signal levels. This may cause the encoder signals to “drift”, causing unrepeatable motion.

Solution: Make sure you have followed the recommendations for the encoder signals as described in the “Installation” section of the user manual. If in doubt about your indexer/controller hookup, contact Teknic.

9. Is the motor cable length excessive?

If you are using an encoder with single ended signaling (not differential), the capacitance of the shielded cable used for the encoder signals should be kept below a certain limit for reliable operation. The capacitance between any encoder signal line and the shield should measure no greater than $[1,000,000,000/F_{\max}]$ picofarads, where F_{\max} is the maximum count frequency of the encoder¹¹. When using commonly available cable (PVC insulated conductors) with Teknic standard motors this works out to a maximum cable length of 25 feet (assuming 100pF/ft and an F_{\max} of 400KHz).

Disconnect your drive-motor extension cable from the drive and the motor. Measure the capacitance of the cable between an encoder phase lead and the shield, to see if it exceeds the limit stated above.¹²

Solutions: **(a)** Use a lower capacitance cable (with perhaps polyethylene or Teflon[®] insulated conductors). **(b)** Reduce the length of the cable. **(c)** Use a balanced encoder.

10. Is the encoder slipping on the motor shaft?

If the encoder is slipping on the motor shaft, unpredictable motion will occur. This is not likely to be a problem with Teknic supplied motors.

To see if this is a problem, remove the motor from the load, make marks on the motor shaft and the encoder collar or disk that line up. Run some aggressive position tuning stimuli and look at the marks. Have they moved with respect to one another? **Solution:** Tighten the encoder mounting, shaft collar, etc. or replace with an encoder rated for higher acceleration.

¹¹ To obtain F_{\max} , the maximum count frequency of the encoder, multiply the line count of the encoder times four and then multiply by the maximum motor speed for the application in revolutions per second.

¹² If you have a capacitance meter with poor resolution in the picofarad range, measure an entire spool of the same cable and then divide the capacitance measured by the number of cables you could make from that length spool.

LOAD MOVES AN INCORRECT, *UNREPEATABLE* DISTANCE

The load moves approximately the correct distance but the distance is not repeatable, and the motor shaft is moving repeatably as verified by the procedure described in the section: “Motor shaft moves an unrepeatable distance”. If so, most likely a problem exists within the mechanics of the system. The following questions may help you narrow down the possibilities and effect an appropriate solution:

- Are the bearings at the load binding?
- Is the belt tension too low?
- Are any coupling set screws slipping?
- Is there excessive lash in the gearbox?
- Is the lineshaft twisting excessively?
- Is the instrument measuring the load position securely mounted so it does not move?

MOTOR “WALKS” WHEN NO STEP PULSES ARE GIVEN

Are the Step and Direction signals wired as specified?

If SSt servo drive “walks”, “hops” or jitters randomly more than a few encoder counts¹³, the problem is most likely the wiring for the Step and Direction signal lines. These high speed inputs respond to conducted noise caused by improper grounding & shielding.

Solution: Explicitly follow the directions for wiring up these signals to the indexer/controller given in the “Installation” section of the user manual.

¹³ Although the SSt™ is vastly superior to most servos with respect to “jitter” or “hunting”, a system that is tuned with high gains to maximize dynamic performance, may still jitter back and forth (by a few encoder counts) around its commanded position when it’s supposed to be still. Turn on “AntiHunt™” in Quick-Set’s main window, and/or reduce the gains to reduce or eliminate this problem.

TORQUE SEEMS LOW

MOTOR MOVES BUT DOES NOT HAVE FULL TORQUE

SYMPTOM SUMMARY

1. **Is the drive-motor cabling correct and intact?**
2. **Is the torque limit set too low?**
3. **Was the proper configuration file loaded?**
—or— **Is the SSt servo drive properly configured to the motor?**
4. **Is the R/O number set incorrectly?**

COMPREHENSIVE ANALYSIS

1. **Is the drive-motor cabling correct and intact?**

Low motor torque can be caused by improper phasing of the motor windings or the commutation sensors. Alternately, there could be a faulty connection within the commutation sensor wiring. If the encoder wiring is intermittent, this can also cause the problem. If you have constructed your own cable or modified a factory supplied cable, improper or poor quality connections could be a problem. Check all of the connections in the cable for shorts or opens.

To check if the phasing of the cable is correct, first disconnect the motor from the load. Make sure that gains Kv, Kp and Ki are at non zero values (If using a Teknic standard motor, load in the standard configuration file for the motor). Then run the Check Sequence procedure (accessed via the “Custom Motor Setup” window) to verify the commutation sensor wiring is correctly phased to the motor leads. If there is an error, SSt-QuickSet™ will tell you. If so, follow the instructions that SSt-QuickSet™ gives you to correct the cable.

Hint: If the cable has been modified, it is likely that a barb on a connector pin has been damaged and/or broken and this can cause a pin to be pushed out.

2. **Is the torque limit set too low?**

Open SSt-QuickSet's™ “Inputs and Limits” window and look at the torque limit. If it is set below 100%, then the torque is being limited by this setting.

Solution: Increase the torque limit setting.

3. **Was the proper configuration file loaded?**
—or— **Is the SSt servo drive properly configured to the motor?**

SSt servo drive drives normally come pre-configured to the motor bundled together in the same package, however, if motor and drive pairs become interchanged and/or if someone has been using a SSt servo drive to experiment with or learn SSt-QuickSet™, then the configuration file may no longer match the motor.

Solutions: (a) If you are using a SSt servo drive system with a Teknic-supplied motor and you are using it for the first time, make sure you load the proper Teknic-supplied configuration file into SSt servo drive. **(b)** If you have previously set up a SSt servo drive with an identical motor and mechanics and have a known-good configuration file that has worked properly in the past for this motor and mechanics, then load in that file.

If you have started with a factory or known-good configuration file and the motor stopped moving after changes were made to the configuration check that the R/O number, Encoder Counts per Turn and the Vector Reference have not been changed. Also check that the Kv, Kp, Kip and Kii gains are not zero. You can easily check all these parameters by using the “Configuration Report” (accessed via the “Setup” menu).

Hint: To view a previous configuration file from disk *without* downloading it into a SSt servo drive, disconnect the SSt servo drive diagnostic cable from your PC and load the file into SSt-QuickSet™. You can then view and/or print the configuration using “Configuration Report” (accessed via the “Setup” menu). You cannot, however, edit the file without SSt servo drive on-line—it handles much of the error checking for the system.

Solutions: (a) Reload the proper factory or known good configuration file. **(b)** Adjust the R/O number, Encoder Counts per Turn, Kip and Kii to the proper values. (Note to adjust the number of steps per revolution *do not* use the Encoder Counts per Turn field in the “Custom Motor Setup” window. This is adjusted using the Steps/rev field in the Inputs and Limits window.)

4. Is the R/O number set incorrectly?

Check the value set in the “Custom Motor Setup” window and compare it to the value on the motor nameplate. These should agree to within 20% (Making them exact will fine-tune the system, but you would need to do this for every system you build.)

Solution(s): (1) If you are using a Teknic supplied motor set the R/O number as marked on the back of the motor. **(2)** Contact Teknic if you need to determine an R/O number for a third-party motor.

MOTOR LOSES TORQUE (OR PERFORMANCE DEGRADES) AFTER RUNNING

SYMPTOM SUMMARY

1. **Is the drive-motor cable loose or does it have intermittent connections or shorts?**
2. **Have the encoder signals been routed to an indexer/controller with low impedance inputs?**
3. **Is the motor cable length excessive?**
4. **Is the encoder slipping on the motor shaft?**

COMPREHENSIVE ANALYSIS

1. **Is the drive-motor cable loose or does it have intermittent connections or shorts?**

If a motor comes up with full torque and then loses the torque after running, the cause could be intermittent encoder signal wiring. Check that the signal lines in the drive-motor cable have no intermittent shorts or opens.

Solution: Repair the cable.

2. **Have the encoder signals been routed to an indexer/controller with low impedance inputs?**

If the encoder signals have been routed to a indexer/controller and are too heavily loaded, they can have marginal signal levels. This may cause the encoder signals to “drift” causing the alignment of the internal sinewave generator to slip. This causes the motor commutation to occur out of phase with the rotor magnetics, thus reducing the torque output.

Solution: Make sure you have followed the recommendations for the encoder signals as described in the “Installation” section of the user manual. If in doubt about your indexer/controller hookup, contact Teknic.

3. **Is the motor cable length excessive?**

If you are using an encoder with single ended signaling (not differential), the capacitance of the shielded cable used for the encoder signals should be kept below a certain limit for reliable operation. The capacitance between any encoder signal line and the shield should measure no greater than $[1,000,000,000/F_{max}]$ picofarads, where F_{max} is the maximum count frequency of the encoder¹⁴. When using commonly available cable (PVC insulated conductors) with Teknic standard motors, this works out to a maximum cable length of 25 feet (assuming 100pF/ft and an F_{max} of 400KHz).

¹⁴ To obtain F_{max} , the maximum count frequency of the encoder, multiply the line count of the encoder times four and then multiply by the maximum motor speed for the application in revolutions per second.

Disconnect your drive-motor extension cable from the drive and the motor. Measure the capacitance of the cable between an encoder phase lead and the shield, to see if it exceeds the limit stated above.¹⁵

Solutions: **(a)** Use a lower capacitance cable (with perhaps polyethylene or Teflon[®] insulated conductors). **(b)** Reduce the length of the cable. **(c)** Use a balanced encoder.

4. Is the encoder slipping on the motor shaft?

If the encoder is slipping on the motor shaft, the alignment of the internal sinewave generator will slip with respect to the motor and this will cause the torque of the motor to drop off. This is not likely to be a problem with Teknic-supplied motors.

To see if this is a problem, remove the motor from the load, make marks on the motor shaft and the encoder collar or disk that line up. Run some aggressive position tuning stimuli and look at the marks. Have they moved with respect to one another? **Solution:** Tighten the encoder mounting, shaft collar, etc. or replace with an encoder rated for higher acceleration.

¹⁵ If you have a capacitance meter with poor resolution in the picofarad range, measure an entire spool of the same cable and then divide the capacitance measured by the number of cables you could make from that length spool.

MISCELLANEOUS (LOW PROBABILITY PROBLEMS)

AXIS “SINGS” OR “WHINES”

SYMPTOM SUMMARY

SSt servo systems have been designed to be nearly silent in operation. If you hear a note when SSt servo drive is operating, it is probably because one or more of the feedback control loops gains is set too high.

1. **Has SSt servo drive been tuned?**
2. **Have the mechanics been changed since SSt servo drive was tuned?**
3. **Have the mechanics become loose or worn?**
4. **Has the proper configuration file been loaded?**
5. **Are the mechanics highly resonant?**

COMPREHENSIVE ANALYSIS

1. **Has SSt servo drive been tuned?**

Each SSt servo drive comes with “stock” tuning which is configured to control the unloaded motor that is paired with the drive. Although this tuning may work when the motor is connected to your mechanical system, it is rarely optimized and should always be tuned for best performance. One symptom of poor tuning is the axis “singing” or “whining” when operating. (This indicates over-tuning, as opposed to under-tuning, which has the symptoms of sluggish and mushy response, among others). **Solution:** Follow the tuning procedure listed in the “Optimizing Performance” section of the user manual.

2. **Have the mechanics been changed since SSt servo drive was tuned?**

If you have changed the mechanics, even slightly, you should re-tune the system and verify performance. Although SSt servo drive has the ability to accommodate widely varying loads with the same tuning, sometimes what appears to be a subtle change in the mechanics can affect the load seen by the motor significantly. Examples of changes that are often overlooked:

- Changing the brand or type of coupling,
- Increasing or decreasing the weight of the load by using different materials,
- Changing the belt type or width,
- Changing the materials of which pulleys are constructed,
- Increasing the length of a drive shaft,
- Changing the overall gearing,
- Changing the gearing of various transmission stages, thus reflecting more inertia back to the motor (even if the overall gear ratio hasn’t changed), and many others...

Solution: Follow the tuning procedure listed in the “Optimizing Performance” section of the user manual after making *any* changes to the mechanical system.

Hint: Teknic offers free simulations designed to estimate the overall performance of any SSt servo drive-driven system. This simulation will give you optimal gearing and acceleration values, as well as much other useful information. Just call Teknic and ask for this applications assistance.

3. Have the mechanics become loose or worn?

Sometimes, if a system has been tuned with high gains to get the best settling and throughput performance, changes in the mechanics due to wear or outright failure can cause the motor to “whine” or “sing”. Typical examples include excessive belt slack, slipping couplings and gear or nut backlash.

Solutions: **(a)** Repair the mechanism and redesign, if possible, to reduce potential of wear, failure. **(b)** De-tune the SSt servo drive so it can tolerate some level of wear. If you are unclear on how to accomplish this, contact Teknic for assistance.

Hint: This same symptom can occur when a system is “tightened up”. For example, a highly resonant system may be obscured by a loose coupling set screw, only to become evident when the coupling is tightened. If this is the case, see the section: “Are the mechanics highly resonant?”.

4. Has the proper configuration file been loaded?

Using the “Configuration Report” command (under the Setup menu), check the tuning parameters against known-good tuning. Especially check Kv, Kip and Kii (listed under tuning information); these are the most likely to cause a high frequency whine when they’re set too high.

5. Are the mechanics highly resonant?

On some mechanisms, you can not get the required performance without turning up the Kv, Kp and Ki gains up to a point where the system is somewhat unstable or oscillatory. This typically happens when there is an undamped spring element in the mechanics and the inertia mismatch is high. Typical components that can cause this include: helical couplings, long drive shafts and cantilevered beam loads.

Solutions: **(a)** The system can be de-tuned in a systematic way to maximize performance and stability, contact Teknic concerning the most effective way to accomplish this. **(b)** Stiffen, remove or damp the spring element(s) in your mechanics; contact Teknic for specific recommendations.

LIMIT SWITCHES DON'T WORK

Are the limit switches physically swapped?

Using your indexer controller, slowly move the axis so that the number in the position display in SSt-QuickSet's™ Status window is increasing. Is the axis moving toward the positive limit switch? If not, the Limit+ and Limit- signals are swapped.

Solution: change the wiring for these switches or leave the wiring connected as it is and physically swap the switches.

ENCODER ERROR SHUTDOWNS OCCUR

The encoder input circuitry on the SSt servo drives is extremely robust. It includes digital filtering and bad sequence detection. The encoders on Teknic motors use Mylar® disks and single chip optics and are also extremely robust. If you get an encoder error *the most likley cause is the encoder wiring* from the motor to the SSt servo drive or between the SSt servo drive back to your controller.

SYMPTOM SUMMARY

1. **Are the encoder signals wired properly?**
2. **Is the motor cable length excessive?**
3. **Does the encoder wiring have intermittent opens or shorts?**
4. **Is the encoder type jumper wire installed on the motor/encoder connector?**
5. **Is a high resolution encoder being used at high speed?**
6. **Is the encoder faulty?**

COMPREHENSIVE ANALYSIS

1. **Are the encoder signals wired properly?**

Have the recommendations for wiring, shielding and grounding of the encoder signals been followed? Please review the recommendations for the drive-motor cable and the encoder wiring in the “Installation” section of this manual. If these have not been followed explicitly this may be the problem.

Solution: Re-wire the drive-motor cable following the recommendations.

2. **Is the motor cable length excessive?**

If you are using an encoder with single-ended signaling (not differential) the capacitance of the shielded cable used for the encoder signals should be kept below a certain limit for reliable operation. The capacitance between any encoder signal line and the shield should measure no greater than $[1,000,000,000/F_{max}]$ picofarads, where F_{max} is the maximum count frequency of the encoder¹⁶. When using commonly available cable (PVC insulated conductors) with Teknic standard motors this works out to a maximum cable length of 25 feet (assuming 100pF/ft and an F_{max} of 400KHz). However for lower cross-talk, more noise immunity and greater engineering margin low capacitance cable is recommended for cables longer than 12 feet.

¹⁶ To obtain F_{max} , the maximum count frequency of the encoder, multiply the line count of the encoder times four (to get the quadrature counts per rev.) and then multiply by the maximum motor speed for the application in revolutions per second.

Disconnect your drive-motor extension cable from the drive and the motor. Measure the capacitance of the cable between an encoder phase lead and the shield, to see if it exceeds the limit stated above.¹⁷

Solutions: **(a)** Use a lower capacitance cable with perhaps polyethylene or Teflon® insulated conductors. *Teknic has tested inexpensive Belden 9935 cable (foamed polyethylene insulation) for use with single-ended encoders at lengths up to 50 feet and F_{max} up to 670 KHz.* **(b)** Reduce the length of the cable. **(c)** Use a balanced encoder.

3. Does the encoder wiring have intermittent opens or shorts?

Open and short circuits in the encoder wiring will cause this type of fault;

Solution: Check and repair the encoder wiring.

4. Is the encoder type jumper wire installed on the motor/encoder connector?

On SSt servo drives used with an unbalanced (TTL) encoder, a jumper between pins 10 and 20 of the motor/encoder connector should be installed. On SSt servo drives used with a balanced (differential) encoder, no jumper wire should be installed between pins 10 and 20 of the motor/encoder connector. If this jumper wire is omitted or inserted in error, poor encoder fidelity will occur causing Encoder error shutdowns and/or erratic operation.

5. Is a high resolution encoder being used at high speed?

Make sure you are not using the motor above the rated operating speed of the encoder or the rated count frequency of the SSt servo drive (2MHz, 20MHz optional). To check this make sure that the maximum operating speed of the motor satisfies:

$$RPM \leq \frac{F_{em} \times 60}{L_c}$$

where: L_c is the line count of the encoder in lines per turn (1/4 of the quadrature counts per turn) and F_{em} is the lower of the maximum operating frequency of the encoder or 500,000.

Solutions: **(a)** Set the speed limit on the SSt servo drive to limit the maximum speed of the motor to a speed below the maximum count frequency of the encoder (contact Teknic for details on how to do this).

(b) Change to a higher speed or lower resolution encoder.

6. Is the encoder faulty?

If the encoder quadrature skew is greater than 90° at any time (causing a faulty count sequence) this will cause an encoder error. Look for bad encoder signals using an oscilloscope. Also check that the signal levels are proper (< 0.5V for a low level and >3.5V for a high level when using a single ended encoder —or— greater than 2.0 Vpp measured differentially when using a balanced encoder). Marginal signals will also trip the bad sequence detection.

Solution: Replace the encoder.

¹⁷ If you have a capacitance meter with poor resolution in the picofarad range measure an entire spool of the same cable and then divide the capacitance measured by the number of cables you could make from that length spool.

DRIVE RESETS WHEN MOTOR ATTEMPTS TO MOVE

SSt servo drive powers up normally and everything appears functional, but when any move or an aggressive move is commanded (either with the “Tuning Stimulus” or your indexer/controller), the drive resets.

Are you using a switching or current limited supply for power?

Most regulated power supplies have current limiting to protect themselves in case of an overload. When high current is drawn from the supply, the voltage drops until the current ceases. This also occurs when using a ferroresonant supply beyond its rated current. When SSt servo drive draws high current to accelerate the load, the power supply voltage will drop until the SSt servo drive shuts off. SSt servo drive will then reset.

Solution: Change the supply to a bulk, linear type with a large output capacitance. A side benefit of changing to this type of supply is that it is generally less expensive anyway.

THERMAL PROTECTION SHUTDOWNS OCCUR

SYMPTOM SUMMARY

1. **Is the ambient temperature at the SSt servo drive above 40 deg. C?**
2. **Is the motor overheating?**
3. **Is there an intermittent short in the thermostat or its wiring?**

COMPREHENSIVE ANALYSIS

1. **Is the ambient temperature at the SSt servo drive above 40 deg. C?**

Solution(s): (a) Relocate SSt servo drive to a cooler operating environment. (b) Mount the SSt servo drive unit vertically if it is now mounted horizontally. (c) Attach a heat sink or mount the SSt servo drive to a machine panel with a good thermal interface compound. (d) Blow air over the SSt servo drive with a fan.

2. **Is the motor overheating?**

Check the temperature of the motor; if you are using a motor with a thermostat this could be tripping because of motor overheating. If you are not using a thermostat, make sure the case temperature of the motor is below its rated limit (75 deg. C/167 deg. F for Teknic supplied motors). Motor overheating could also be a sign that the SSt servo drive is being used beyond its rating and, in rare instances, this can cause a thermal Ready within the SSt servo drive.

To find and cure the source of the motor heating problem see the "Motor runs hot" section.

3. **Is there an intermittent short in the thermostat or its wiring?**

If you have a short in the thermostat wiring it will appear that the motor is overheating. Solution: Remove the cause of the short.

APPENDIX A: SST-1500 SPECIFICATIONS

General	Dimensions: 7.310" x 4.876" x 1.156" Weight: 20oz (567g)
Environmental	Temperature: 0%-90% non-condensing Humidity: 0°C-40°C
Supply Requirements	Input Voltage: 24-75VDC Nominal Input Current: 150mA quiescent, peak is application and motor dependent (max. peak is 12A)
Output	PWM Frequency: 20KHz Current Capability: 7A RMS in any mounting configuration in free air; 9A RMS mounted vertically on a metallic bulkhead; 11.5A RMS mounted vertically with forced air cooling. 23A Peak (3 seconds)
Protection:	Protected on a cycle-by-cycle basis against phase-to-phase shorts and shorts to ground. Fused.
Encoder Input	Type: TTL or differential incremental encoder inputs with or without index. Digitally filtered with bad sequence detection Rate: Maximum Rate: 2.0MHz, (20MHz optional) Courtsey Power: SSt servo drive can supply +5V @ 200mA.
Step & Direction Inputs	Isolated Format: TTL level Schmidt triggered inputs with 470 ohm pull-up resistors to +5VDC Maximum rate: 2MHz (20MHz optional)
Real-time Monitor Port	Format: 0.5-4.5V analog signal (0=2.5V) Features: Configurable digital filtering, Sync pulse at beginning of moves, wide scaling factors (high zoom), non-volatile configuration. Variables: actual velocity, commanded velocity, tracking (position) error, velocity error, commanded torque, actual torque.
Vector Commutation	Vector Error: 0.1% or less Type: Sinewave—Indirect, voltage vector dq current control with PI compensator with proprietary enhancements. Calculation Rate: 10kHz
Analog Command Input	Format: Differential voltage input, ±10 range. Impedance: Greater than 10K Scale: Digitally programmable via configuration port in velocity mode. Fixed at 10% of output capability per volt in torque mode.

APPENDIX B: CONNECTORS

Shown below are the connector pin-outs on the SST-1500 drive, and not those on the opposite end of Teknic cables—they are not necessarily the same. Your motor, controller and limit cables are likely to have different mating pin-outs depending on the connector used on the end of the cable away from the drive. For example, see page 15 for the motor-side connector pin-out for a Teknic motor.

Note: The figures below show the view looking *into* the SST-1500's connectors. (These diagrams can also be interpreted at the wire-end-view of the mating connectors.)

Motor/Encoder

Molex Minifit type, mates with P/N 39-01-2200

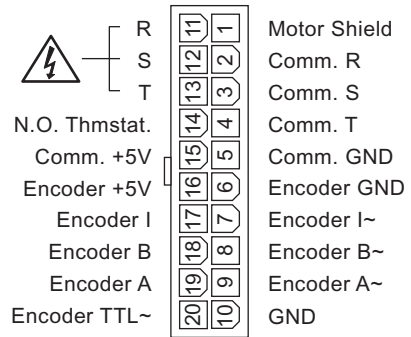

Controller

Molex Minifit type, mates with P/N 39-01-2180

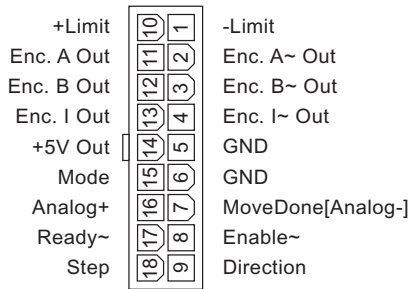

Limits

Molex Minifit type, mates with 39-01-2060

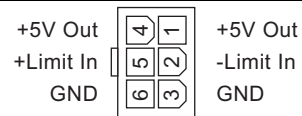

Power

AMP Universal Mate-N-Lock, mates with 1-480-698-0

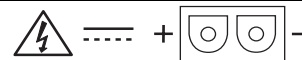

Real-time Monitor port & QuickSet™ Configuration port&

Molex .120" pocket header, mates with 50-57-9405

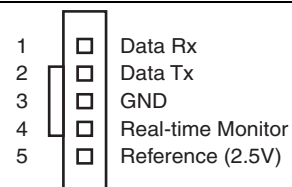

INDEX

- Acceleration Feedforward Tuning, **66**
- All Windings Off, 17
- Analog Input Wiring, **21**
- AntiHunt™, **65**
- Application Note
 - Clamping or Inserting Objects, **46**
 - Error Recovery, **48**
 - Homing Axes, **45**
 - Manual Calibrations, **47**
 - Monitor Port, **58**
 - Move Completion, **44**
 - Optical Interrupter Limit Switches, **19**
 - Secondary Encoder, **48**
 - Torque Foldback, **46**
 - Use with Servo Controller, **21**
 - Watching Positioning Errors, **45**
- Axial Loading, **42**
- Axis “sings”, **105**
- Axis Jerks at Beginning of Moves, **92**
- Axis Jerks at End of Move, **89**
- Bearing Life, **42**
- Benefits, **1**
 - Ease of Use, 3
 - Efficient, 3
 - Expanded Torque-speed, 1
 - High Bandwidth, 2
 - Low Jitter, 2
 - Reliable, 3
 - Smooth motion, 2
- Built-In Instrumentation, **56**
- Cable
 - Controller, 8, 11
 - Diagnostic, 29
 - Encoder, 8
 - Flexible, **14**
 - Limit Switch, 8
 - Motor, 8, 14
 - Power, 7
 - SSt-CC, 12
- Compensator, **54, 56**
- Configuration Cable, 29
- Configuration Port, **29**
- Connectors, **113**
 - Controller, 10
 - Diagnostic, **29**
 - Motor, 15
 - Power Input, **25**
- Control Algorithms, **55**
- Controller
 - Interfacing, **10**
- Controller Cable, 8
- Controller Interface, 8
- Custom Motors, **30**
- Daisy Chain Power, 6, 7
- Diagnostic Cable, 29
- Diagnostic Connector, **29**
- Differential Encoder, 23
- Disable Drive, **17**
- Drive Resets When Motor Attempts to Move, **110**
- Drive Shuts Down, **74**
- Drive Won't Respond, **52**
- Electrical
 - Isolation, **6**
 - Power, 7
- Electrical Installation, **5**
- Eliminating Servo Jitter, **69**
- Enable Input, **17, 97**
- Encoder Cable, 8
- Encoder Error Shutdowns, **108**
- Encoder Feedback, **44**
- Encoder Interface, 22
 - Differential, 23
 - Single Ended, 22
 - Termination, **23**
 - Wiring - Differential, **23**
 - Wiring - Single-Ended, **22**
- Erratic Communication, **53**
- Feature
 - Hard Stop Homing, 47
 - Torque Foldback, 46, 47
- Feedforward Gain, **54**
- Following Error, **54**
- Fuse, 7, 30, 86
- Gains, **54**
- Glossary, **54**
- Grounding, **6, 7, 10**
- Hard Stop Homing, 47
- I/V shutdowns, **82**
- Illustration
 - Kp Tuning, 64
 - PIV Compensator, 56
 - Typical Velocity Response, 61
 - Unstable Velocity Loop, 62
 - Velocity Feedforward, 63
- Incorrect Moves
 - Repeatable, **95**
 - Unrepeatable, **99**
- Indexer Interface, 8
- Indicator
 - Power/Fuse (RED), **30**
 - Status (Green), **74**
- Inputs, **17**
 - Enable, **17, 97**
 - Limit, **18**
 - Mode, **18**

- Step & Direction, **15**
- Thermostat, **30**
- Typical Circuit, **17**
- Inputs & Limits Window, **52**
- Installation
 - Grounding, **7, 10**
 - Power Supply Wiring, **7**
 - Shielding, **7**
- Instrumentation, **56**
- Integrator
 - Tuning, **65, 69, 70**
- Interfacing
 - Controller, **8**
 - Indexer, **8**
 - Limit Switches, **8**
- Isolation
 - Electrical, **6**
- Kill, **18**
- Lack of Movement, **85**
- Large velocity/torque ripple, **94**
- Limit Cycle, **65**
- Limit Switch
 - Cable, **8**
- Limit Switch Cheater Plug, **19**
- Limit Switches, **8**
- Limit Switches Don't Work, **107**
- Logic Input Circuit, **17**
- Logic Outputs, **19**
- Loops, **55**
- Main Window, **51**
- Mechanical Installation, **31**
- Minimizing Settling Time, **70**
- Mode Input, **18**
- Monitor port, **29, 54, 56, 58**
- Monitor Port, **58**
- Motion erratic, **93**
- Motor
 - cable, **8**
 - Interfacing, **14**
 - Wiring, **14**
- Motor "Walks" with No Step Pulses, **100**
- Motor Outline
 - M-1726-FX, **33**
 - M-2330-FH, **35**
 - M-2330-FX, **34**
 - M-2330-XH, **34**
 - M-2330-XX, **33**
 - M-2348-FH, **37**
 - M-2348-FX, **36**
 - M-2348-XH, **36**
 - M-2348-XX, **35**
 - M-3437-FX, **38**
 - M-3437-XX, **37**
 - M-3450-XX, **38, 39**
 - M-3462-FH, **40**
 - M-3471-FH, **41**
 - M-497P-FI, **41**
 - M-497T-FI, **41**
- Motor Phase Cable, **8**
- Mounting
 - SSt-1500-□C□, **31**
 - SSt-1500-□L□, **32**
- Move Length Incorrect, **95**
- Movement Not Smooth, **89**
- Offline, **52**
- Optical Interrupter Limits, **19**
- Oscilloscope Setup, **58**
- Outputs
 - MoveDone, **20**
 - Ready, **20**
 - Shutdown, **20**
 - Typical Circuit, **20**
- Overshoot, **55**
- Over-Travel Limit Inputs, **18**
- Performance Degrades, **103**
- PIV, **55**
- PIV Compensator, **56**
- Position Error, **55**
- Position Integrator, **55**
- Position Loop Tuning, **63**
- Power Supply, **24**
 - Current Requirements, **26**
 - Daisy Chain, **6, 7**
 - Peak Currents, **26**
 - Quick Sizing, **26**
 - RMS Current Calculation, **27**
 - Rules, **7**
- Radial Loading, **42**
- Real-Time Monitor port, **29, 58**
- Reversing Step & Direction Sense, **17**
- Ringing, **55**
- RMS Current Calculation, **27**
 - Continuous Velocity, **28**
 - Incremental Positioning, **27**
 - Incremental Positioning / Reduced Output, **28**
- RMS Limit Shutdowns, **76**
- RS-232 Port, **29**
- Servo Controller Usage, **21**
- Servo Glossary, **54**
- Servo Jitter, **69**
- Setting up your Oscilloscope, **58**
- Settling Time, **55**
- Setup
 - Monitor Port, **58**
 - Oscilloscope, **58**
- Shaft Loading Specifications, **42**
- Shielding, **7**
- Shutdown
 - Clearing Existing, **18**
 - Encoder, **108**
 - I/V, **82, 84**

- Output Line, **20**
- Over-Current/Voltage, **7**
- Position Tracking, **45**
- RMS, 61, 64, **76**, 79
- Thermal, **111**
- Tracking Error, **74**
- Single Ended Encoder, **22**
- Smooth Response, **68**
- Specification
 - Shaft Loading, **42**
- Specifications, **112**
- SSt-CC, **13**
- SSt-DC, **29**
- SSt-MC, **15**
- SSt-QuickSet, **50**
 - Inputs & Limits Window, **52**
 - Main Window, **51**
- Static Precautions, **9**
- Step & Direction
 - Polarity, **17**
 - Reversing Direction, **17**
 - Signals, **15**
 - Timing, **16**
 - Wiring, **16**
- Stiffness, **55**
- Stimulus Generator, **57**
- Termination
 - Encoder Inputs, **23**
- Thermal Protection Shutdowns, **111**
- Thermostat, **30**
- Torque Foldback, **47**
- Torque Saturation, 74, **91**
- Torque Seems Low, **101**
- Tracking Error, **55**
- Troubleshooting, **72**
 - Axis “sings”, **105**
 - Axis Jerks at Beginning of Moves, **92**
 - Axis Jerks at End of Move, **89**
 - Drive resets When Motor Attempts to Move, **110**
 - Drive Shuts Down, **74**
 - Encoder Error Shutdowns, **108**
 - I/V shutdowns, **82**
 - Incorrect Moves (unrepeatable), **99**
 - Incorrect Repeatable Moves, **95**
 - Lack of Movement, **85**
 - Large velocity/torque ripple, **94**
 - Limit Switches Don't Work, **107**
 - Motion erratic, **93**
 - Motor “Walks” With No Step Pulses, **100**
 - Move Length Incorrect, **95**
 - Movement Not Smooth, **89**
 - Performance degrades, **103**
 - RMS Limit Shutdowns, **76**
 - Thermal Protection Shutdowns, **111**
 - Torque Seems Low, **101**
 - Unrepeatable Moves, **96**
- Tuning, **54**
 - Acceleration Feedforward, **66**
 - AntiHunt™, **65**
 - Eliminating Servo Jitter, **69**
 - For Performance, **59**
 - Integrator, **69**
 - Integrator Tuning, **65**
 - Minimum Settling Time, **70**
 - Position Loop, **63**
 - Smoothest Response, **68**
 - Tailoring the Response, **67**
 - Velocity Loop, **60**
- Tuning Stimulus, **56**, **57**
- Unrepeatable Moves, **96**
- Velocity Error, **55**
- Velocity Feedforward Adjustments, **63**
- Voltage Saturation, 74, **91**
- Wiring
 - Analog Inputs, **21**
 - Controller, **8**
 - Encoder(Differential), **23**
 - Encoder(Single-Ended), **22**
 - Power, **25**